

**Dinah Zike's**  
**Teaching Mathematics**  
**with**  **FOLDABLES™**

**Author**

**Dinah Zike, M. Ed.**  
Educational Consultant  
San Antonio, Texas



**Glencoe**  
**McGraw-Hill**

New York, New York   Columbus, Ohio   Chicago, Illinois   Peoria, Illinois   Woodland Hills, California

**Glencoe/McGraw-Hill**

A Division of The McGraw-Hill Companies



Copyright © by The McGraw-Hill Companies, Inc. All rights reserved. Printed in the United States of America. Except as permitted under the United States Copyright Act, no part of this publication may be reproduced or distributed in any form or by any means, or stored in a database or retrieval system, without the prior written permission of the publisher.

Send all inquiries to:  
Glencoe/McGraw-Hill  
8787 Orion Place  
Columbus, OH 43240

Part of ISBN 0-07-830413-X

*Teaching Mathematics with Foldables*

1 2 3 4 5 6 7 8 9 10 045 11 10 09 08 07 06 05 04 03 02

# Table of Contents

Letter from Dinah Zike . . . . .	v	<b>Projects Using Folds</b>	
<b>Introduction to Foldables</b>		Billboard Project . . . . .	32
Why Use Foldables in Mathematics? . . . . .	vi	Sentence-Strip Holder . . . . .	33
Correlation of Foldables to		Sentence Strips . . . . .	34
<i>Glencoe Mathematics</i> . . . . .	vii	<b>Math Activities using Foldables</b>	
Foldable Basics . . . . .	1	<b>Number Systems</b>	
Selecting the Appropriate Foldable . . . . .	3	Whole Numbers . . . . .	35
<b>Folding Instructions</b>		Integers . . . . .	36
<b>Basic Foldable Shapes</b> . . . . .	5	Integers: Adding and Subtracting . . . . .	37
<b>1-Part Folds</b>		Integers: Multiplying and Dividing . . . . .	38
Half Book . . . . .	6	Rational Numbers . . . . .	39
Folded Book . . . . .	7	Rational Numbers: Fractions . . . . .	40
Bound Book . . . . .	8	Rational Numbers: Decimals . . . . .	41
Two-Tab Book . . . . .	9	Percents . . . . .	42
<b>2-Part Folds</b>		Ratios . . . . .	43
Matchbook . . . . .	10	Proportions . . . . .	43
Pocket Book . . . . .	11	Irrational Numbers . . . . .	44
Shutter Fold . . . . .	12	Real Number System . . . . .	44
<b>3-Part Folds</b>		<b>Algebraic Patterns and Functions</b>	
Trifold Book . . . . .	13	Sets and Variables . . . . .	45
Three-Tab Book . . . . .	14	Expressions . . . . .	46
Three-Tab Book Variations . . . . .	15	Properties . . . . .	47
Pyramid Fold or Mobile . . . . .	16	Equations . . . . .	48
<b>4-Part Folds</b>		Inequalities . . . . .	49
Layered-Look Book . . . . .	17	Relations and Functions . . . . .	50
Four-Tab Book . . . . .	18	Factors . . . . .	51
Envelope Fold . . . . .	19	Multiples . . . . .	52
Standing Cube . . . . .	20	Monomials and Polynomials . . . . .	53
Four-Door Book . . . . .	21	Powers and Exponents . . . . .	54
Top-Tab Book . . . . .	22	Sequences . . . . .	55
Accordion Book . . . . .	24	Matrices . . . . .	56
<b>Any Number of Parts</b>		<b>Geometry</b>	
Pop-Up Book . . . . .	25	Points . . . . .	57
Folding into Fifths . . . . .	26	Lines and Line Segments . . . . .	57
Folded Table, Chart, or Graph . . . . .	27	Rays . . . . .	57
Folding a Circle into Tenths . . . . .	28	Angles . . . . .	58
Circle Graph . . . . .	29	Angle Relationships . . . . .	58
Concept-Map Book . . . . .	30	Planes . . . . .	59
Vocabulary Book . . . . .	31	Polygons . . . . .	60
		Triangles . . . . .	61
		Right Triangles . . . . .	62
		Right Triangle Trigonometry . . . . .	63

Quadrilaterals . . . . .	.64	Permutations . . . . .	.81
Squares, Rectangles, and Rhombi . . . . .	.65	Combinations . . . . .	.81
Parallelograms . . . . .	.66	Probability . . . . .	.82
Trapezoids . . . . .	.67	Scatter Plots . . . . .	.83
Circles . . . . .	.68	<b>Problem Solving</b>	
Three-Dimensional Figures . . . . .	.69	Problem-Solving Plan . . . . .	.84
Prisms and Cylinders . . . . .	.70	Problem-Solving Strategies . . . . .	.84
Pyramids and Cones . . . . .	.71	<b>Communication</b>	
Coordinate Geometry . . . . .	.72	Vocabulary and Writing Definitions . . . . .	.85
Slope . . . . .	.73	Journals . . . . .	.85
Graphing Equations and Inequalities . . . . .	.74	Outline, List, and Sequence . . . . .	.86
<b>Measurement</b>		Concept Maps . . . . .	.86
Metric Measurement . . . . .	.75	Writing Instructions . . . . .	.86
Length, Width, and Height . . . . .	.75	Main Ideas and Note Taking . . . . .	.87
Distance . . . . .	.76	Annotations . . . . .	.87
Weight . . . . .	.76	Questioning . . . . .	.87
Volume . . . . .	.77	<b>Representation</b>	
Temperature . . . . .	.77	Tables and Charts . . . . .	.88
<b>Data Analysis and Probability</b>		Circle Graphs . . . . .	.88
Statistics . . . . .	.78	Bar Graphs and Histograms . . . . .	.89
Stem-and-Leaf Plots . . . . .	.79	Line Graphs . . . . .	.89
Box-and-Whisker Plots . . . . .	.79	Pictographs . . . . .	.90
Fundamental Counting Principle . . . . .	.80	Venn Diagrams . . . . .	.90
Frequency Tables . . . . .	.80	<b>Index</b> . . . . .	.91
Pascal’s Triangle . . . . .	.80		

## Dear Teacher,

In this book, you will find instructions for making Foldables as well as ideas on how to use them. They are an excellent communication tool for students and teachers.

### **National Math Standards and Communication Skills**

The Principles and Standards for School Mathematics, published by the National Council of Teachers of Mathematics (NCTM) in 2000, stress the importance of communication skills in a strong mathematics program. Not all students will become mathematicians, engineers, or statisticians, but all students need to be able to think, analyze, and problem solve using skills acquired through the study of mathematics.

Throughout their lives, students will be called upon to be literate in mathematics—personally and professionally. They will need to have a basic understanding of numbers, operations, and quantitative reasoning; patterns, relationships, and algebraic thinking; geometry; measurement; and probability and statistics to solve real-life problems involving finances, chance, design, science, fine arts, and more.

Furthermore, students must be able to share the results of their use of mathematics using various forms of oral and written communication. Foldables are one of many techniques that can be used to integrate reading, writing, thinking, organizing data, researching, and other communication skills into an interdisciplinary mathematics curriculum.

### **Who, What, When, Why**

You probably have seen at least one of the Foldables featured in this book used in supplemental programs or staff-development workshops. Today, my Foldables are used internationally. I present workshops and keynotes to over fifty thousand teachers and parents a year, sharing the Foldables that I began inventing, designing, and adapting over thirty years ago. Around the world, students of all ages are using them for daily work, note-taking activities, student-directed projects, forms of alternative assessment, math journals, graphs, charts, tables, and more.

### **Add and Amend**

After workshop presentations, participants would ask me for lists of activities to be used with the Foldables they had just learned to make. They needed help visualizing how to convert math data into Foldables. So, over fifteen years ago, I began collecting and sharing the ideas listed in this book. The ideas are organized by topic. The table for each topic shows the math content being addressed and an appropriate Foldable. I hope you enjoy making Foldables a part of your math classroom!



# Why Use Foldables in Mathematics?

When teachers ask me why they should take time to use the Foldables featured in this book, I explain that they

- . . . quickly organize, display, and arrange information, making it easier for students to grasp math concepts and master skills.
- . . . result in student-made study guides that are compiled as students listen for main ideas, read for main ideas, and work their way through new concepts and procedures.
- . . . provide a multitude of creative formats in which students can present projects, research, and computations instead of typical poster board or math fair formats.
- . . . replace teacher-generated writing or photocopied sheets with student-generated print.
- . . . incorporate the use of such skills as comparing and contrasting, recognizing cause and effect, and finding similarities and differences into daily work and long-term projects. For example, these Foldables can be used to compare and contrast student explanations and procedures for solving problems to the explanations presented by other students and teachers.
- . . . continue to “immerse” students in previously learned vocabulary and concepts, providing them with a strong foundation that they can build upon with new observations, experiences, and knowledge.
- . . . can be used by students or teachers to easily communicate data through graphs, tables, charts, models, and diagrams, including Venn diagrams.
- . . . allow students to make their own math journals for recording main ideas, problem-solving strategies, examples, questions that arise during classwork, and personal experiences that occur during learning.
- . . . can be used as alternative assessment tools by teachers to evaluate student progress or by students to evaluate their own progress.
- . . . integrate language arts, the sciences, and social sciences into the study of mathematics.
- . . . provide a sense of student ownership in the mathematics curriculum.

## Correlation of Foldables™ to Glencoe Mathematics

Foldable™ Topic	<i>Mathematics: Applications and Connections, Course 1</i>	<i>Mathematics: Applications and Connections, Course 2</i>	<i>Mathematics: Applications and Connections, Course 3</i>	<i>Pre-Algebra</i>	<i>Algebra 1</i>	<i>Geometry</i>	<i>Algebra 2</i>
<b>Number Systems</b>							
Whole Numbers	✓	✓	✓	✓			
Integers	✓	✓	✓	✓	✓		
Integers: Adding and Subtracting	✓	✓	✓	✓			
Integers: Multiplying and Dividing	✓	✓	✓	✓			
Rational Numbers	✓	✓	✓	✓	✓		
Rational Numbers: Fractions	✓	✓	✓	✓			
Rational Numbers: Decimals	✓	✓	✓	✓			
Percents	✓	✓	✓	✓	✓		
Ratios	✓	✓	✓	✓			
Proportions	✓	✓	✓	✓	✓		
Irrational Numbers				✓	✓		✓
Real Number System				✓	✓		✓
<b>Patterns and Functions</b>							
Sets and Variables	✓	✓	✓	✓	✓		✓
Expressions	✓	✓	✓	✓	✓		✓
Properties	✓	✓	✓	✓	✓		✓
Equations	✓	✓	✓	✓	✓		✓
Inequalities	✓	✓	✓	✓	✓		✓
Relations and Functions	✓	✓	✓	✓	✓		✓
Factors	✓	✓		✓	✓		
Multiples	✓	✓		✓	✓		
Monomials and Polynomials			✓	✓	✓		✓
Powers and Exponents	✓	✓	✓	✓	✓		✓
Sequences				✓	✓	✓	✓
Matrices			✓		✓	✓	✓
<b>Geometry</b>							
Points	✓	✓	✓	✓	✓	✓	✓
Lines and Line Segments			✓	✓		✓	
Rays						✓	
Angles	✓	✓	✓	✓		✓	✓
Angle Relationships						✓	
Planes						✓	
Polygons	✓	✓	✓	✓		✓	
Triangles	✓	✓	✓	✓		✓	
Right Triangles	✓	✓	✓	✓	✓	✓	✓

## Correlation of Foldables™ to Glencoe Mathematics

Foldable™ Topic	<i>Mathematics: Applications and Connections, Course 1</i>	<i>Mathematics: Applications and Connections, Course 2</i>	<i>Mathematics: Applications and Connections, Course 3</i>	<i>Pre-Algebra</i>	<i>Algebra 1</i>	<i>Geometry</i>	<i>Algebra 2</i>
Algebra and Right Triangles				✓	✓	✓	✓
Quadrilaterals	✓	✓		✓		✓	
Squares, Rectangles, and Rhombi	✓	✓	✓	✓		✓	
Parallelograms	✓	✓		✓		✓	
Trapezoids		✓	✓	✓		✓	
Circles	✓	✓	✓	✓		✓	
Three-Dimensional Figures	✓	✓	✓	✓		✓	
Prisms and Cylinders	✓	✓	✓	✓		✓	
Pyramids and Cones			✓	✓		✓	
Coordinate Geometry	✓	✓	✓	✓	✓	✓	✓
Slope		✓	✓	✓	✓	✓	✓
Graphing Equations and Inequalities		✓	✓	✓	✓	✓	✓
<b>Measurement</b>							
Metric Measurement	✓						
Length, Width, and Height	✓						
Distance	✓						
Weight	✓						
Volume	✓						
Temperature	✓	✓	✓	✓	✓		
<b>Data Analysis and Probability</b>							
Statistics							
Stem-and-Leaf Plots	✓						
Box-and-Whisker Plots		✓		✓	✓		
Fundamental Counting Principle		✓	✓	✓	✓		✓
Frequency Tables	✓	✓	✓	✓			
Pascal's Triangle			✓	✓	✓	✓	✓
Permutations		✓	✓	✓	✓		✓
Combinations		✓	✓	✓	✓		✓
Probability	✓	✓	✓	✓	✓	✓	✓
Scatter Plots		✓	✓	✓	✓	✓	✓
<b>Problem Solving</b>							
Problem Solving Plan	✓	✓	✓	✓	✓	✓	✓
Problem Solving Strategies	✓	✓	✓	✓	✓		
<b>Communication</b>							
Vocabulary and Writing Definitions	✓	✓	✓	✓	✓	✓	✓



## *Correlation of Foldables™ to Glencoe Mathematics*

Foldable™ Topic	<i>Mathematics: Applications and Connections, Course 1</i>	<i>Mathematics: Applications and Connections, Course 2</i>	<i>Mathematics: Applications and Connections, Course 3</i>	<i>Pre-Algebra</i>	<i>Algebra 1</i>	<i>Geometry</i>	<i>Algebra 2</i>
Journals	✓	✓	✓	✓	✓	✓	✓
Outline, List, and Sequence	✓	✓	✓	✓	✓	✓	✓
Concept Map	✓	✓	✓	✓	✓	✓	✓
Writing Instructions	✓	✓	✓	✓	✓	✓	✓
Main Ideas and Note Taking	✓	✓	✓	✓	✓	✓	✓
Annotations	✓	✓	✓	✓	✓	✓	✓
Questioning	✓	✓	✓	✓	✓	✓	✓
<b>Representation</b>							
Tables and Charts	✓	✓	✓	✓	✓	✓	✓
Circle Graphs	✓	✓	✓	✓		✓	
Bar Graphs and Histograms	✓	✓	✓	✓	✓		
Line Graphs	✓	✓					
Pictographs	✓						
Venn diagrams	✓	✓	✓	✓	✓	✓	✓



# Foldable Basics

## What to Write and Where

Teach students to write general information—titles, vocabulary words, concepts, questions, main ideas, and properties or theorems—on the front tabs of their Foldables. General information is viewed every time a student looks at a Foldable. Foldables help students focus on and remember key points without being distracted by other print.

Ask students to write specific information—supporting ideas, student thoughts, answers to questions, research information, computation steps, class notes, observations, and definitions—under the tabs.

As you teach, demonstrate different ways in which Foldables can be used. Soon you will find that students make their own Foldables and use them independently for study guides and projects.

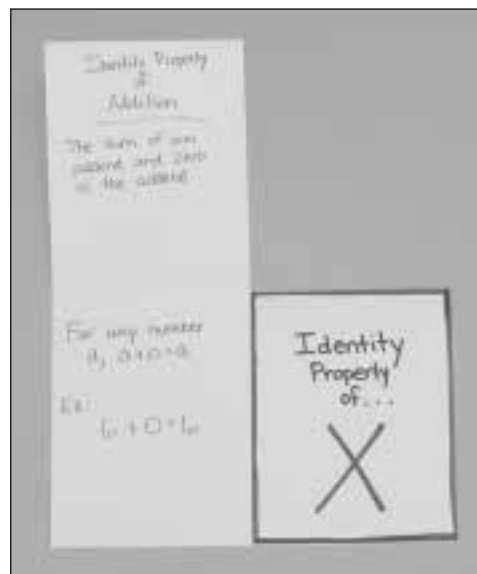
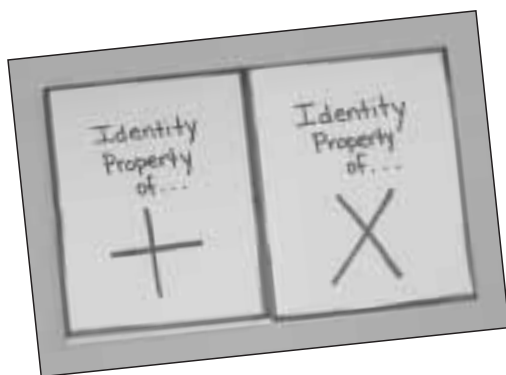

## With or Without Tabs

Foldables with flaps or tabs create study guides that students can use to self check what they know about the general information on the front of the tabs. Use Foldables without tabs for assessment purposes or projects where information is presented for others to view quickly.

Venn Diagram used as a study guide

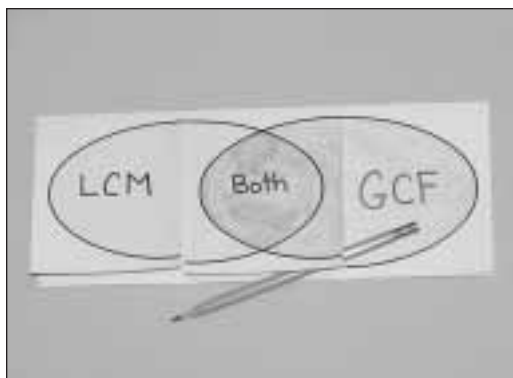

Venn Diagram used for assessment

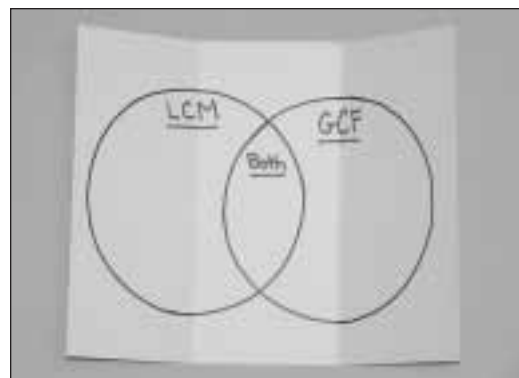

## What to Do with Scissors and Glue

I don't expect secondary students to bring glue and scissors to math class. Instead, I set up a small table in the classroom and provide several containers of glue, numerous pairs of scissors (sometimes tied to the table), containers of markers and colored pencils, a stapler, clear tape, and anything else I think students might need to make their Foldables. Don't be surprised if students donate unusual markers, decorative-edged scissors, gel pens, stencils, and other art items to your publishing table.



The more they make and use graphic organizers, the faster students become at producing them.

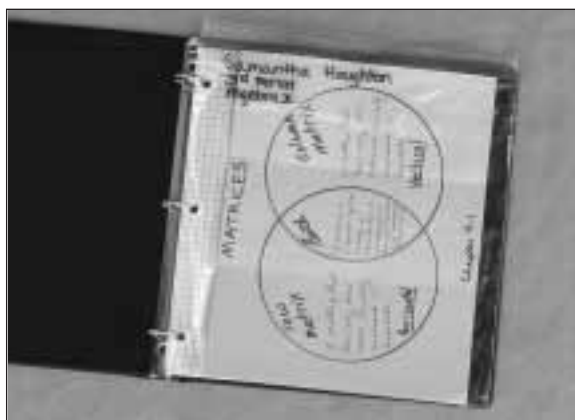

## Storing Graphic Organizers in Student Portfolios

Turn one-gallon freezer bags into student portfolios which can be collected and stored in the classroom. Students can also carry their portfolios in their notebooks if they place strips of two-inch clear tape along one side and punch three holes through the taped edge.

Have each student write his or her name along the top of the plastic portfolio with a

permanent marker and cover the writing with two-inch clear tape to keep it from wearing off.

Cut the bottom corners off the bag so it won't hold air and will stack and store easily.

**HINT:** *I found it more convenient to keep student portfolios in my classroom so student work was always available when needed and not "left at home" or "in the car." Giant laundry-soap boxes make good storage containers for portfolios.*

## Let Students Use This Book As an Idea Reference

Make this book available to students to use as an idea reference for projects, discussions, extra credit work, cooperative learning group presentations, and more.

# Selecting the Appropriate Foldable

## *Dividing Math Concepts into Parts*

Foldables divide information and make it visual. In order to select the appropriate Foldable, decide how many parts you want to divide the information into and then determine which Foldable best illustrates or fits those parts. Foldables that are three-dimensional also make the student interact with the information kinesthetically.

For example, if you are studying the Properties of Equality you could choose a Foldable that has five tabs (or sections). On the front tabs write the properties. Under the tabs, explain the properties in words on one side and in symbols on the other side.

<b>Math Concepts Already Divided into Parts</b>					
<i>Algebra</i>		<i>Geometry</i>		<i>Statistics and Probability</i>	
<b>Parts</b>	<b>Concept</b>	<b>Parts</b>	<b>Concept</b>	<b>Parts</b>	<b>Concept</b>
5	Properties of Equality	2	collinear and noncollinear	3	mean, median, mode
3	parentheses, brackets, and braces	2	complementary and supplementary angles	1	Fundamental Counting Principle
2	equations and inequalities	2	parallel and perpendicular	4	Who, What, When, Where: Blaise Pascal
2	numeric and algebraic expressions	3	translation, rotation, reflection	2	permutations and combinations
2	domain and range	6	types of triangles	2	upper quartile and lower quartile
7	properties of addition and multiplication	4	SSS, SAS, ASA, AAS	2	dependent and independent events
2	LCM and LCD	2	two types of special right triangles	2	probability and odds
3	monomials, binomials, and trinomials	6	types of quadrilaterals	2	odds in favor and odds against
2	powers and exponents	2	$x$ -axis and $y$ -axis	2	mutually inclusive and exclusive events

<b>Math Concepts That Can Be Divided into Parts</b>		
<i>Algebra</i>	<i>Geometry</i>	<i>Statistics and Probability</i>
write algebraic expressions	draw angles with a protractor	determine ranges of sets
evaluate expressions	classify polygons	interpret scatter plots
sequence steps	illustrate quadrilaterals	display data collected in plots
list algebraic rules	list examples of prisms	draw models of combinations
solve equations	name ordered pairs	
find values for variables	graph points	

## ***Dividing Skills and Foldables into Parts***

Reading, writing, and thinking skills can easily be used with Foldables. The following lists show examples of skills and activities and a selection of Foldables divided into parts. You may want to refer to this page as you select activities from the lists of math topics in this book. (See pages 35–90.)

<b>Skills and Activities Divided into Parts</b>	
<b>1 Part</b>	<b>2 Parts</b>
Find the Main Idea	Compare and Contrast
Predict an Outcome	Cause and Effect
Narrative Writing	Similarities and Differences
Descriptive Writing	Opposite Operations
Expository Writing	
Persuasive Writing	
<b>3 Parts</b>	<b>4 Parts</b>
Venn Diagrams	Who, What, When, Where
Know?-Like to Know?-Learned?	What, Where, When, Why/How
Beginning, Middle, End	
<b>Any Number of Parts</b>	
Questioning	Making and Using Tables
Flow Charts	Making and Using Graphs
Vocabulary Words	Making and Using Charts
Timelines	Sequencing Data or Events
Concept Webs or Maps	

<b>Foldables Divided into Parts</b>	
<b>1 Part</b>	<b>2 Parts</b>
Half Book	Two-Tab Book
Folded Book	Pocket Book
Matchbook	Shutter Fold
Bound Book	Matchbook Cut in Half
	Concept-Map Book with Two Tabs
<b>3 Parts</b>	<b>4 Parts</b>
Trifold Book	Four-Tab Book
Three-Tab Book	Standing Cube
Pyramid Book	Top-Tab Book
Layered-Look Book	Four-Door Book
Concept Map with Three Tabs	
<b>Any Number of Parts</b>	
Accordion Book	Circle Graph
Layered-Look Book	Concept-Map Book
Sentence-Strip Holder	Vocabulary Book
Folded Table, Chart, or Graph	Bound Book
Pyramid Mobile	Pocket Books
Top-Tab Book (three or more sheets of paper)	

# Basic Foldable Shapes

The following figures illustrate the basic folds that are referred to throughout the following section of this book.

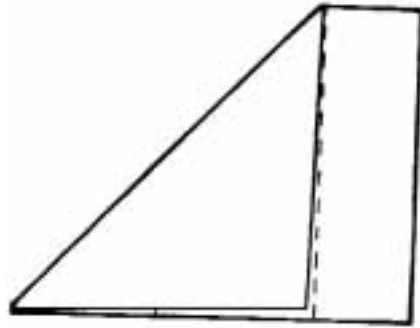

**Taco Fold**

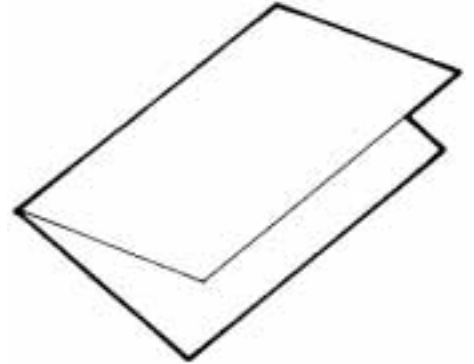

**Hamburger Fold**

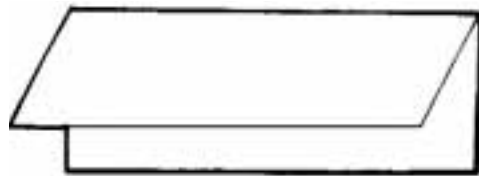

**Hot Dog Fold**

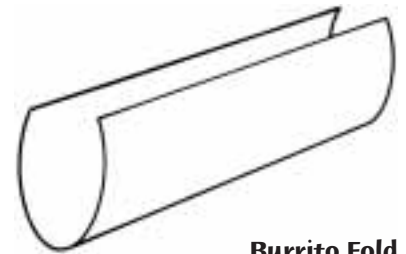

**Burrito Fold**

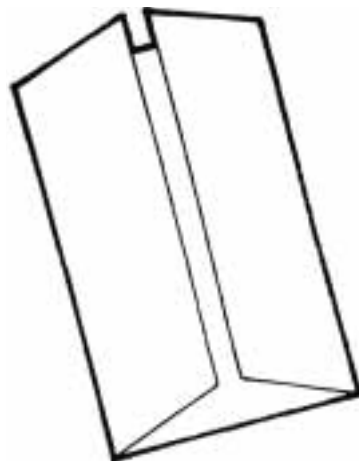

**Shutter Fold**

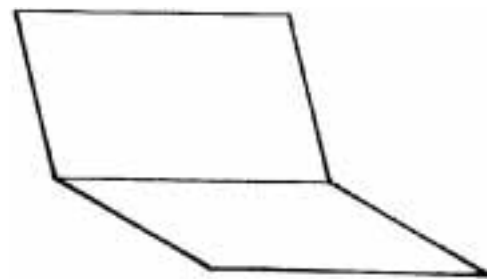

**Valley Fold**

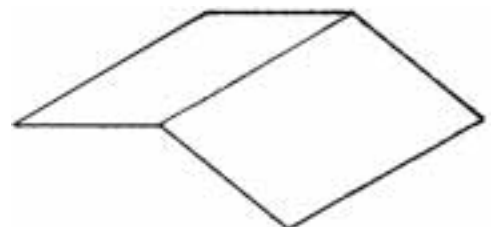

**Mountain Fold**

# Half Book

Fold a sheet of  $8\frac{1}{2}'' \times 11''$  paper in half.

1. This book can be folded vertically like a *hot dog* or . . .
2. . . it can be folded horizontally like a *hamburger*.

Use this book for descriptive, expository, persuasive, or narrative math writing, as well as graphs, diagrams, or charts.





# Folded Book

1. Make a *half book*.
2. Fold it in half again like a *hamburger*. This makes a ready-made cover, and two small pages for information on the inside.

Use photocopied worksheets, Internet print outs, and student-drawn diagrams or maps to make this book. One sheet of paper can be used for two activities and two grades.

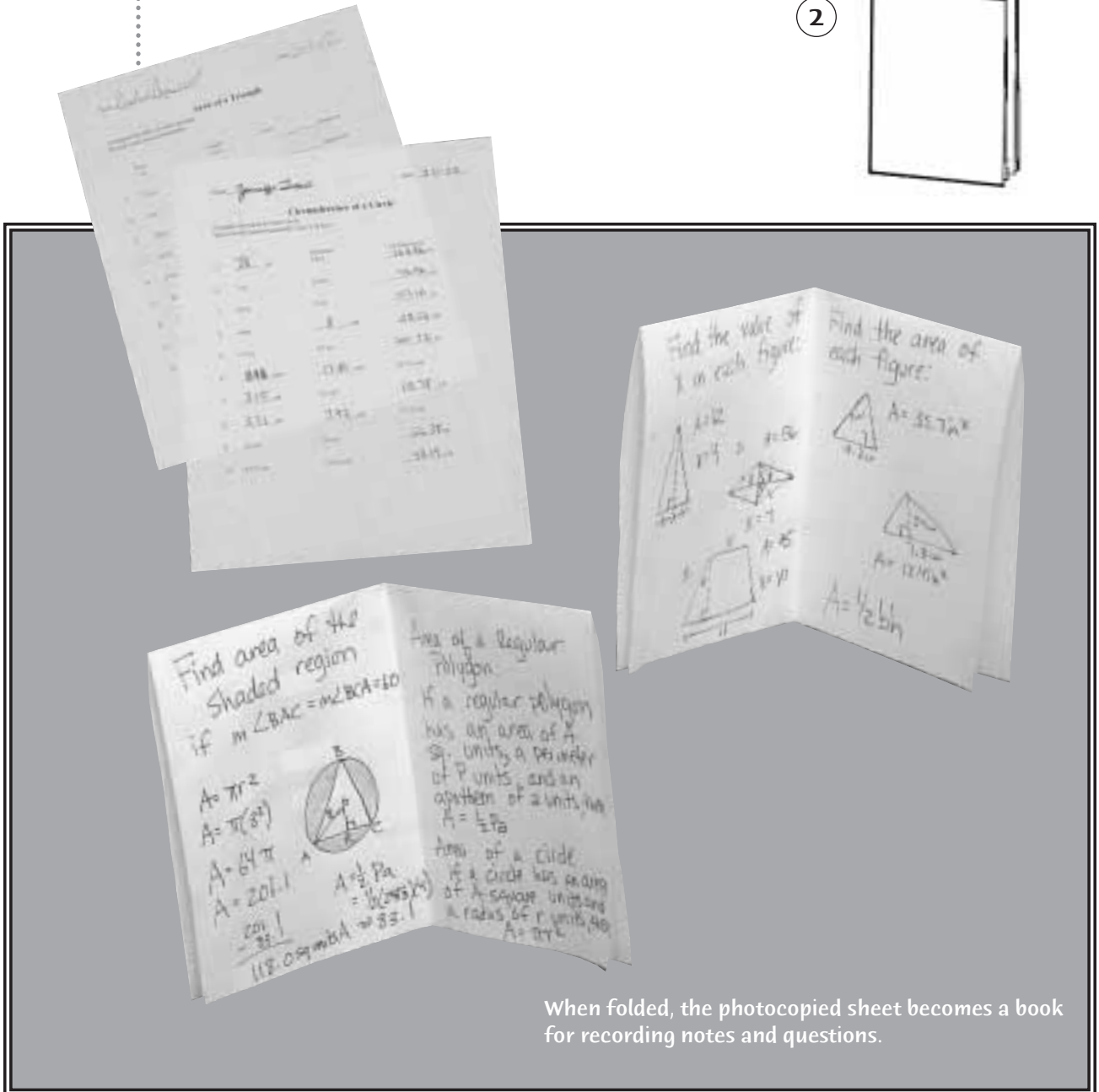
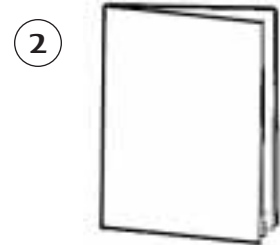
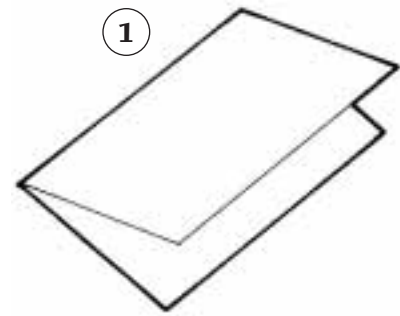

When folded, the photocopied sheet becomes a book for recording notes and questions.

# Bound Book

1. Take two sheets of  $8\frac{1}{2}'' \times 11''$  paper and fold each one like a *hamburger*. Place the papers on top of each other, leaving one sixteenth of an inch between the *mountain tops*.
2. Mark both folds one inch from the outer edges.
3. On one of the folded sheets, cut from the top and bottom edge to the marked spot on both sides.
4. On the second folded sheet, start at one of the marked spots and cut the fold between the two marks.
5. Take the cut sheet from step 3 and fold it like a *burrito*. Place the *burrito* through the other sheet and then open the *burrito*. Fold the bound pages in half to form an eight-page book.

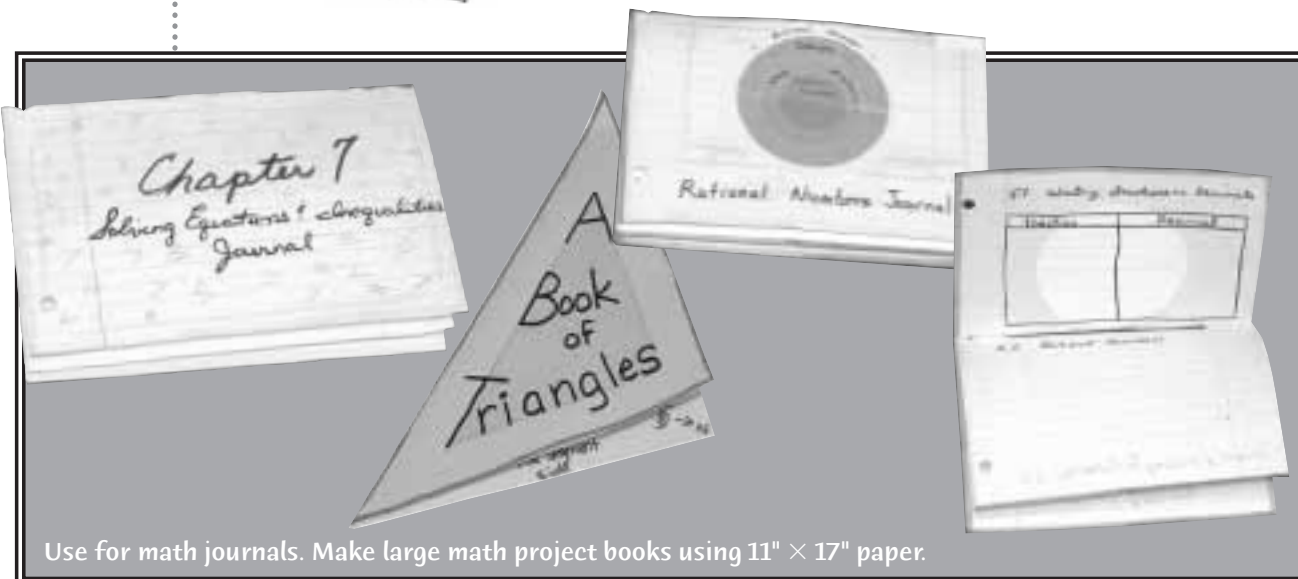
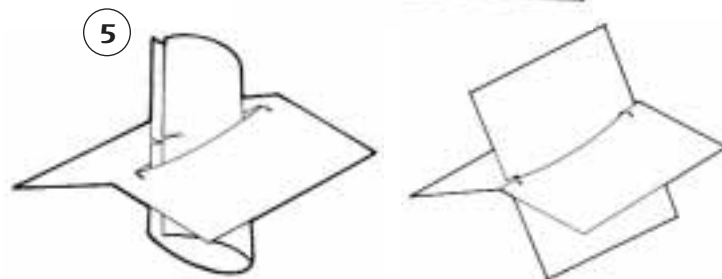
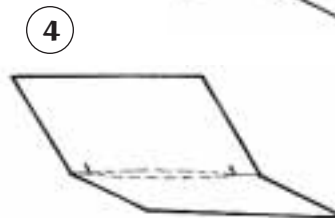
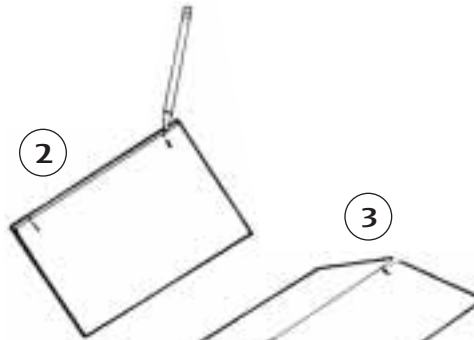
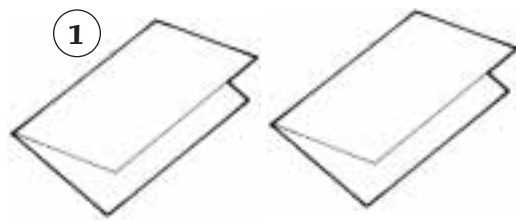

Use for math journals. Make large math project books using  $11'' \times 17''$  paper.

# Two-Tab Book

1. Take a *folded book* and cut up the *valley* of the inside fold toward the *mountain top*. This cut forms two large tabs that can be used front and back for writing and illustrations.
2. The book can be expanded by making several of these folds and gluing them side-by-side.

Use this book for data that occurs in twos, for example opposite operations.

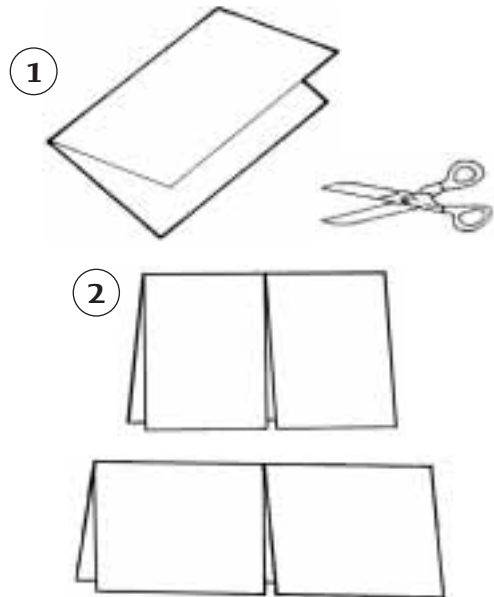

# Matchbook

1. Fold a sheet of  $8\frac{1}{2}'' \times 11''$  paper like a *hamburger*, but fold it so that one side is one inch longer than the other side.
2. Fold the one-inch tab over the short side forming an envelope-like fold.
3. Cut the front flap in half toward the *mountain top* to create two flaps.

Use this book to report on one or two vocabulary words, questions, or concepts. Collect matchbooks and use them to make great student-made bulletin boards.

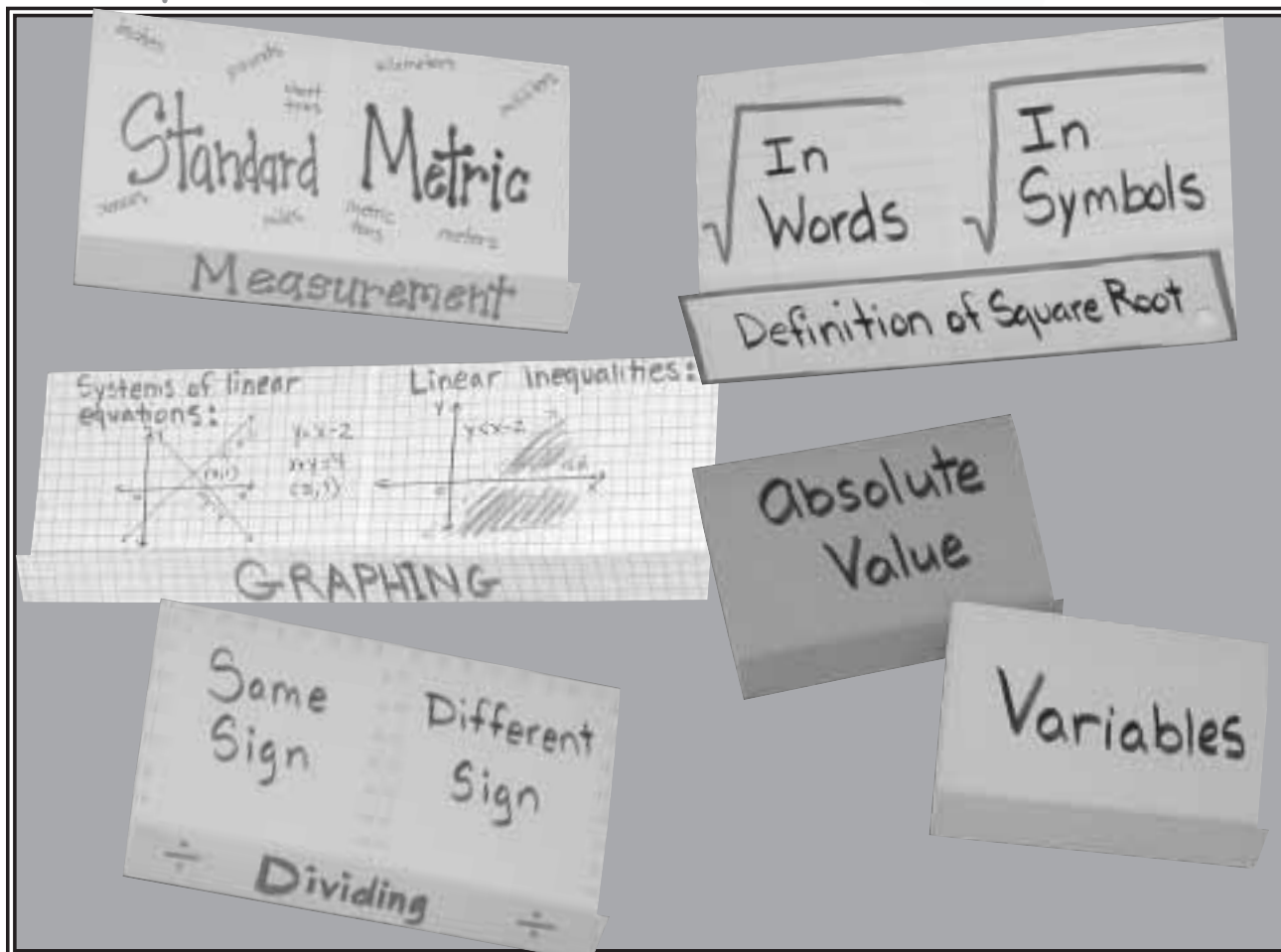
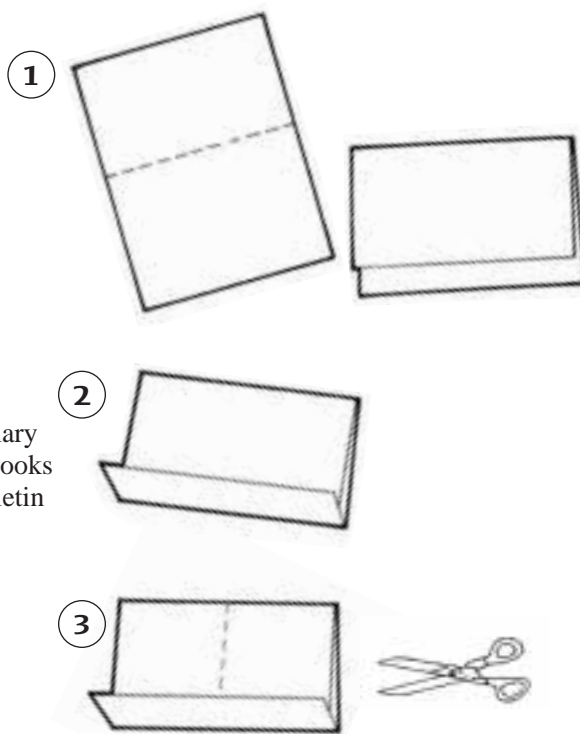

# Pocket Book

1. Fold a sheet of  $8\frac{1}{2}'' \times 11''$  paper in half like a *hamburger*.
2. Open the folded paper and fold one of the long sides up two inches to form a pocket. Refold along the *hamburger* fold so that the newly formed pockets are on the inside.
3. Glue the outer edges of the two-inch fold with a small amount of glue.
4. **Optional:** Glue a cover around the *pocket book*.

**Variation:** Make a multi-paged booklet by gluing several pockets side-by-side. Glue a cover around the multi-paged *pocket book*.

Use  $3'' \times 5''$  index cards inside the pockets. Store student-made books, such as two-tab books and folded books in the pockets.

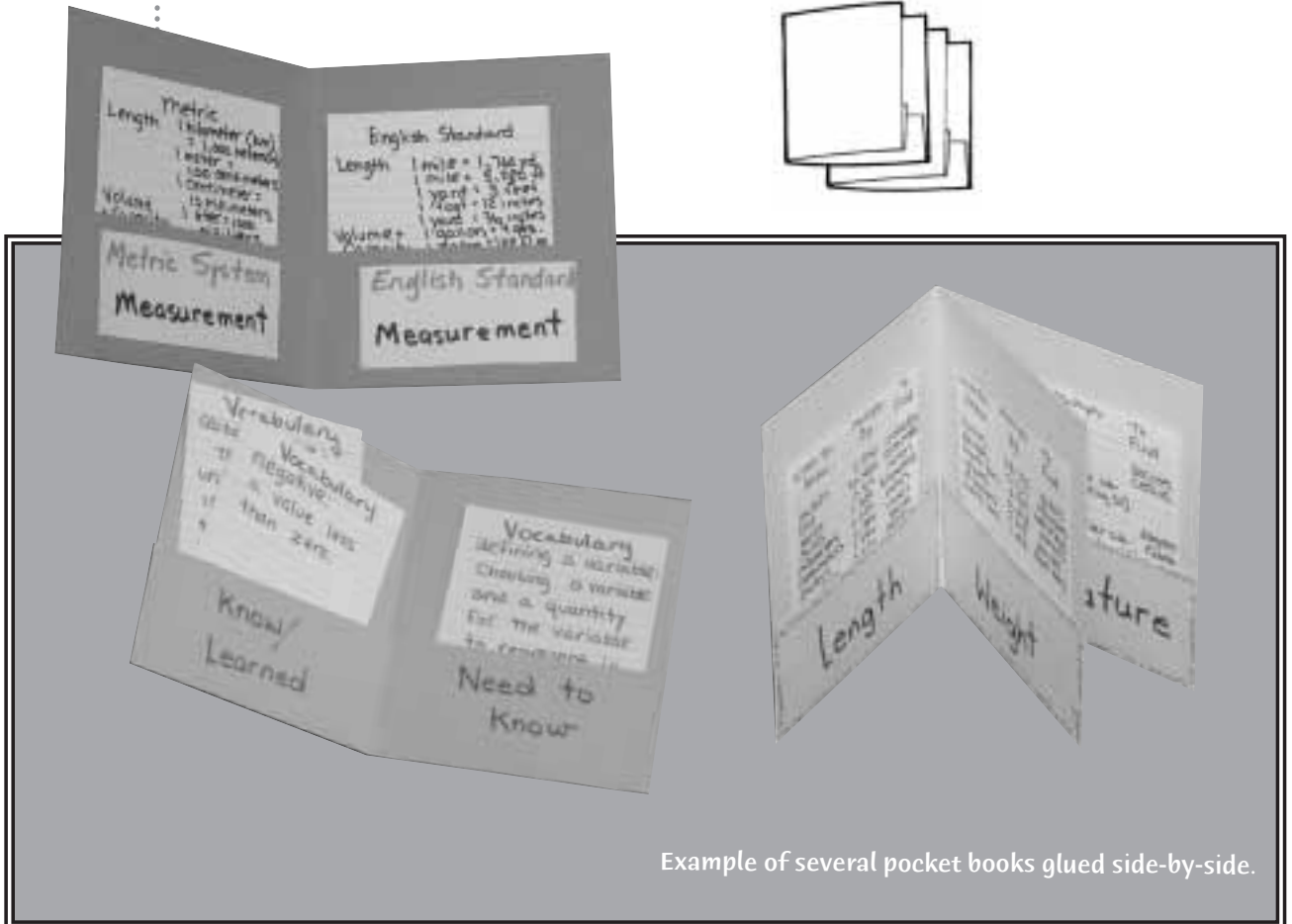
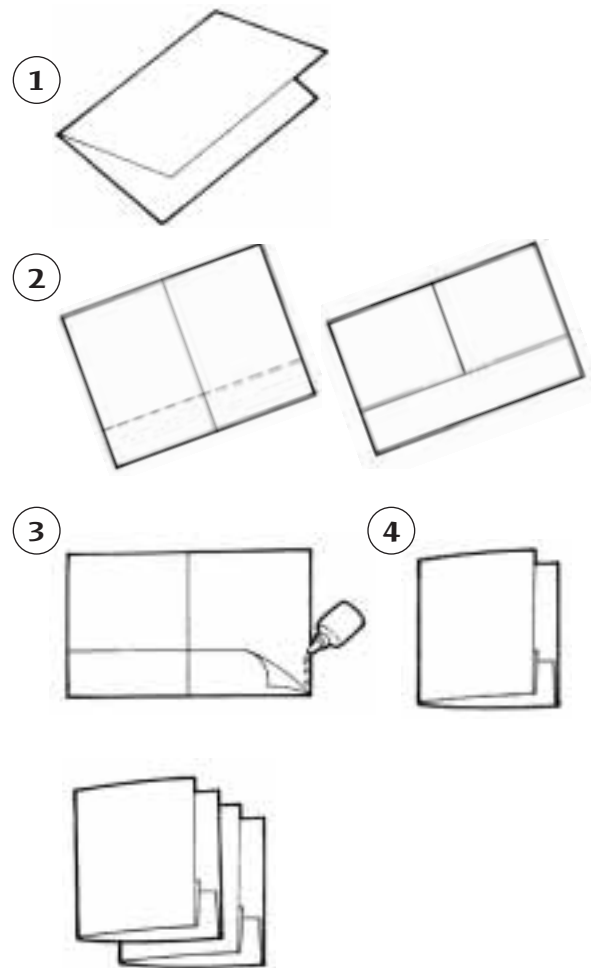

Example of several pocket books glued side-by-side.

# Shutter Fold

1. Begin as if you were going to make a *hamburger* but instead of creasing the paper, pinch it to show the midpoint.
2. Fold the outer edges of the paper to meet at the pinch, or mid-point, forming a *shutter fold*.

Use this book for data occurring in twos. Or, make this fold using 11" × 17" paper and smaller books—such as the half book, journal, and two-tab book—that can be glued inside to create a large project full of student work.

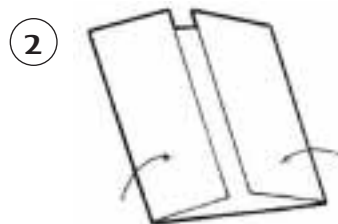
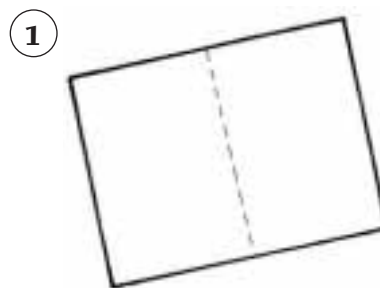

# Trifold Book

1. Fold a sheet of  $8\frac{1}{2}'' \times 11''$  paper into thirds.
2. Use this book as is, or cut into shapes. If the trifold is cut, leave plenty of fold on both sides of the designed shape, so the book will open and close in three sections.

Use this book to make charts with three columns or rows, large Venn diagrams, or reports on data occurring in threes.

1

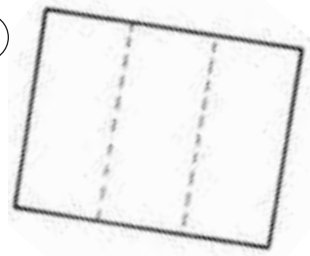

2

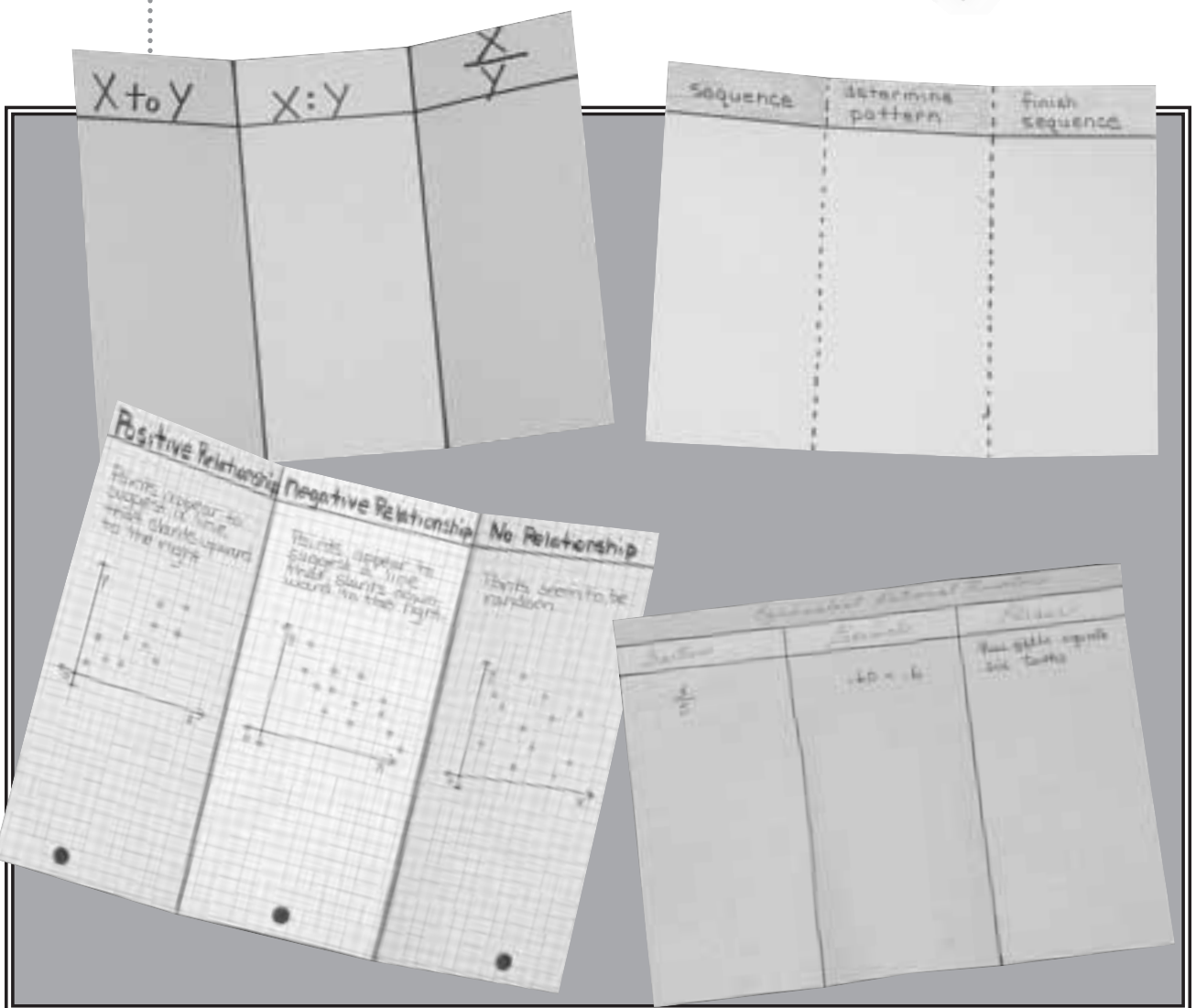
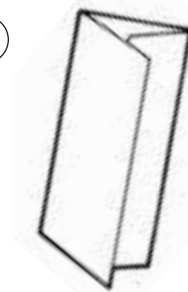

# Three-Tab Book

1. Fold a sheet of paper like a *hot dog*.
2. With the paper horizontal, and the fold of the *hot dog* up, fold the right side toward the center, trying to cover one half of the paper.

**NOTE:** If you fold the right edge over first, the final graphic organizer will open and close like a book.

3. Fold the left side over the right side to make a book with three folds.
4. Open the folded book. Place your hands between the two thicknesses of paper and cut up the two *valleys* on one side only. This will form three tabs.

Use this book for data occurring in threes.

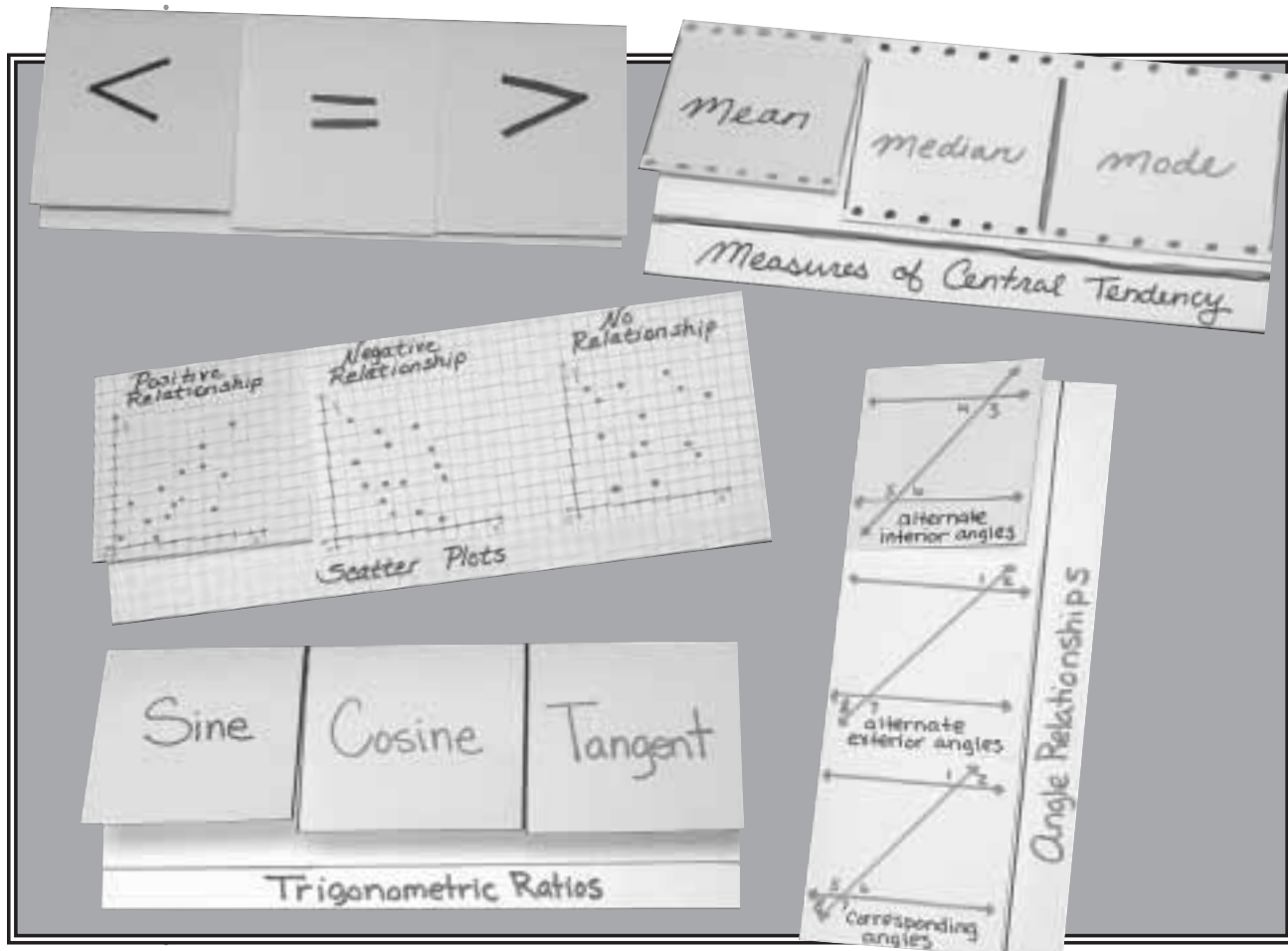
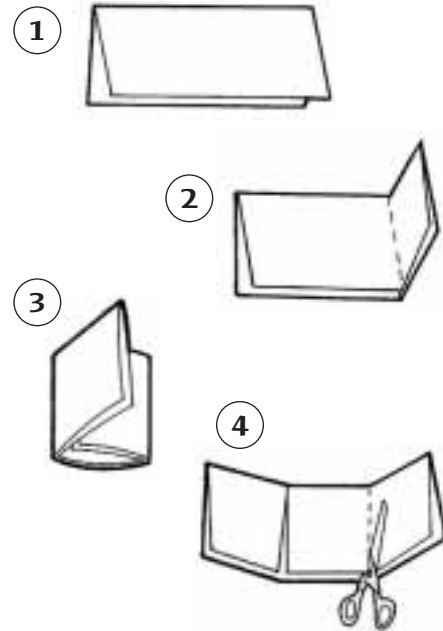



# Three-Tab Book Variations

## Variation A

Draw overlapping circles on the three tabs to make a Venn Diagram.



## Variation B

Cut each of the three tabs in half to make a six-tab book.

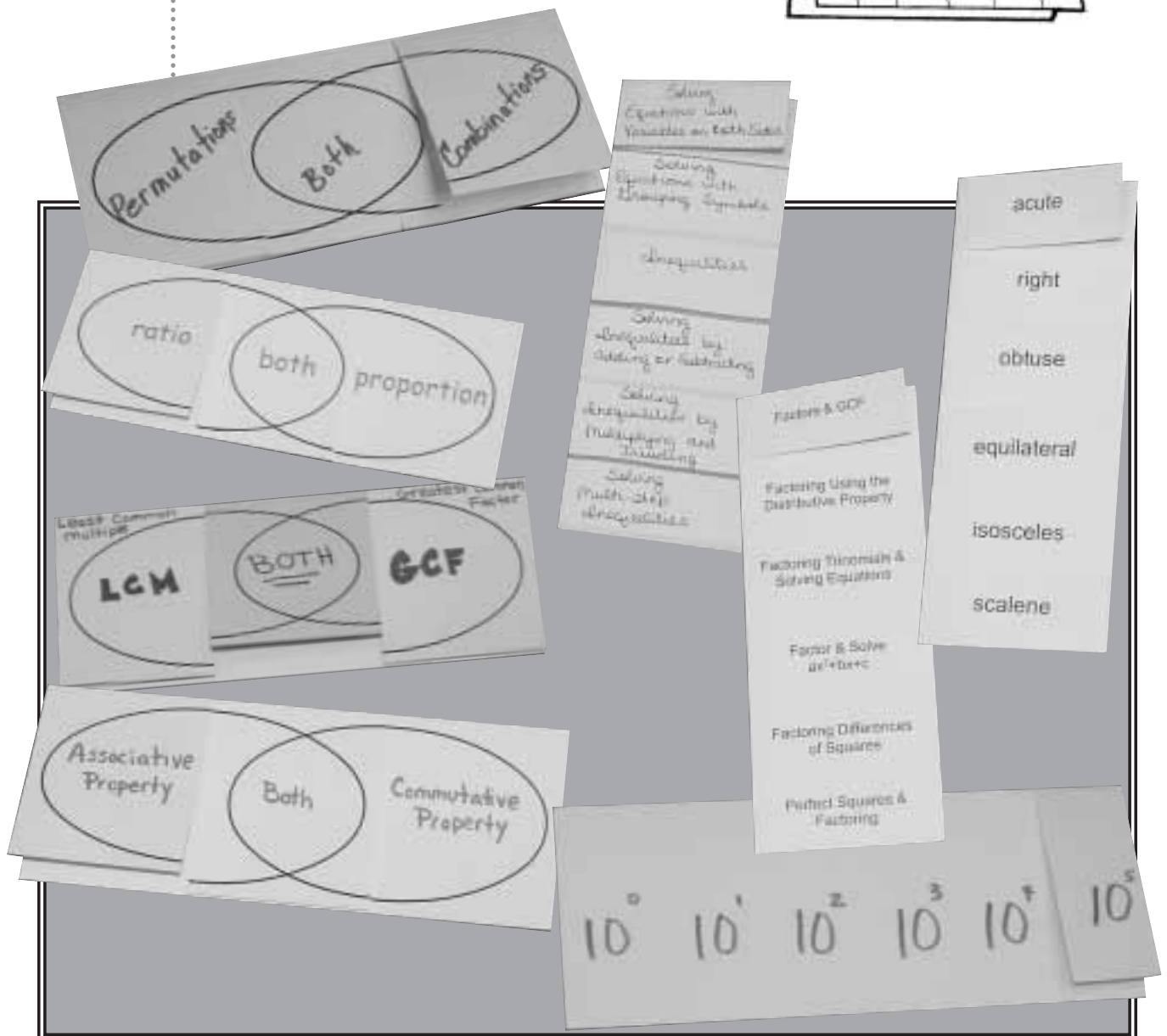
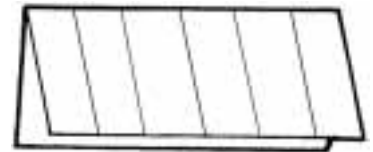

# Pyramid Fold or Mobile

1. Fold a sheet of  $8\frac{1}{2}'' \times 11''$  paper into a *taco*, forming a square. Cut off the excess rectangular tab formed by the fold.
2. Open the folded *taco* and refold it the opposite way forming another *taco* and an X-fold pattern.
3. Cut one of the folds to the center of the X, or the midpoint, and stop. This forms two triangular-shaped flaps.
4. Glue one of the flaps under the other, forming a *pyramid*.
5. Label front sections and write information, notes, thoughts, and questions inside the pyramid on the back of the appropriate tab.

Use to make mobiles and dioramas.  
Use with data occurring in threes.

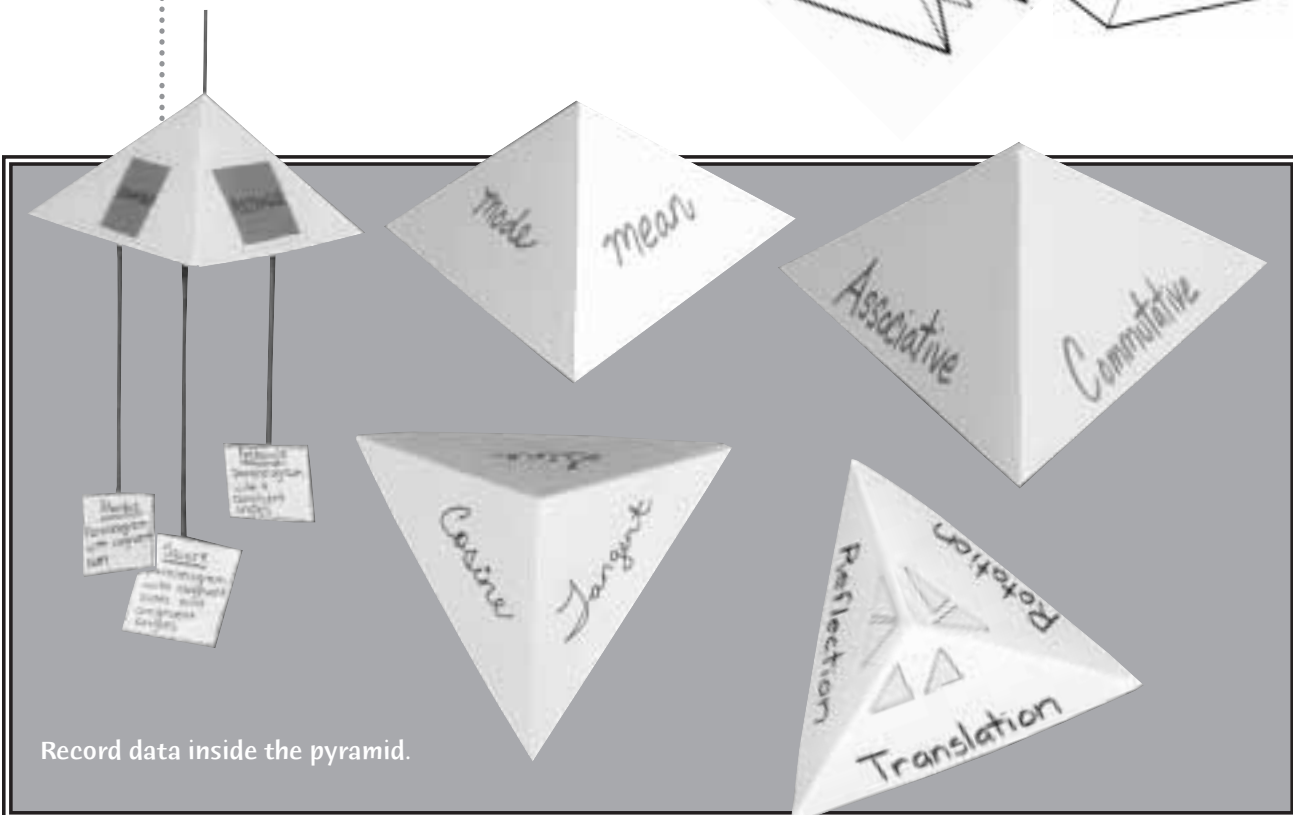
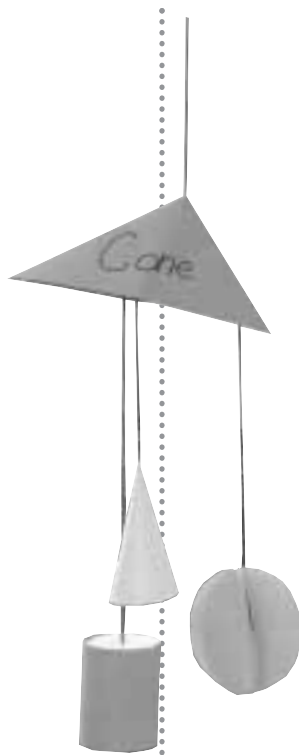
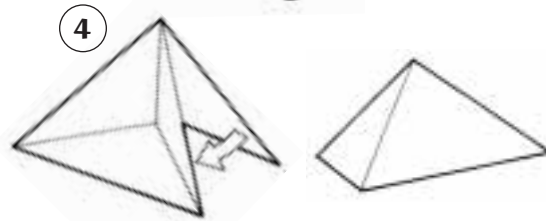
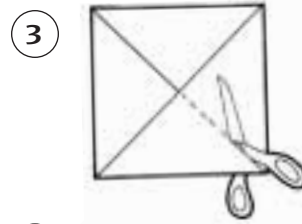
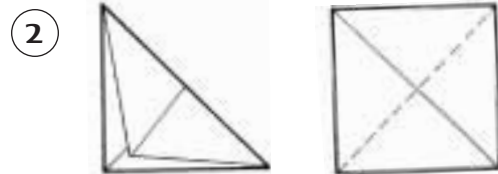
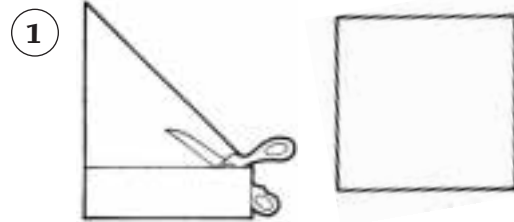

Record data inside the pyramid.

# Layered-Look Book

- Stack two sheets of  $8\frac{1}{2}'' \times 11''$  paper so that the back sheet is one inch higher than the front sheet.
- Bring the bottom of both sheets upward and align the edges so that all of the layers or tabs are the same distance apart.
- When all tabs are an equal distance apart, fold the papers and crease well.
- Open the papers and glue them together along the *valley* or inner center fold or, staple them along the mountain.

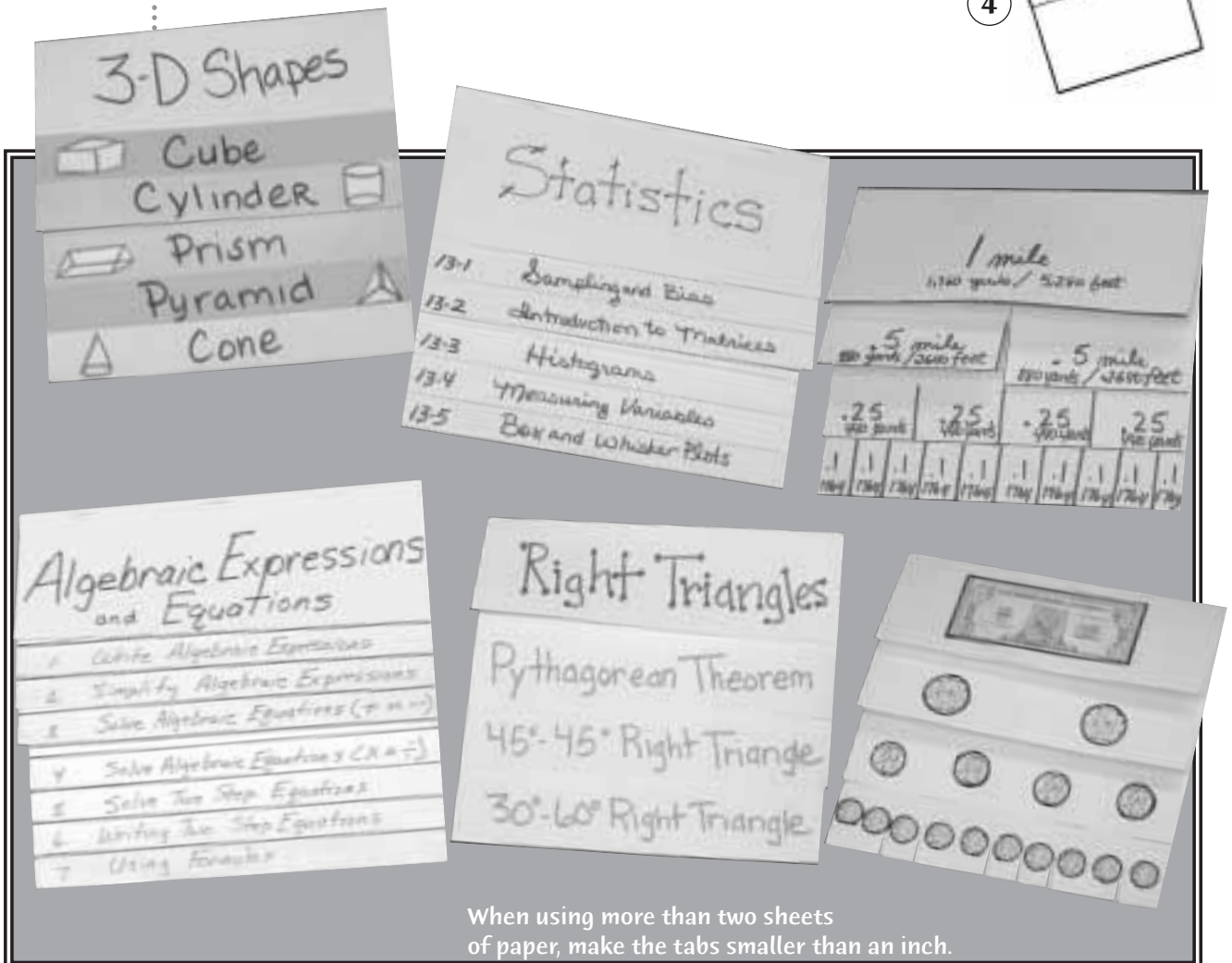
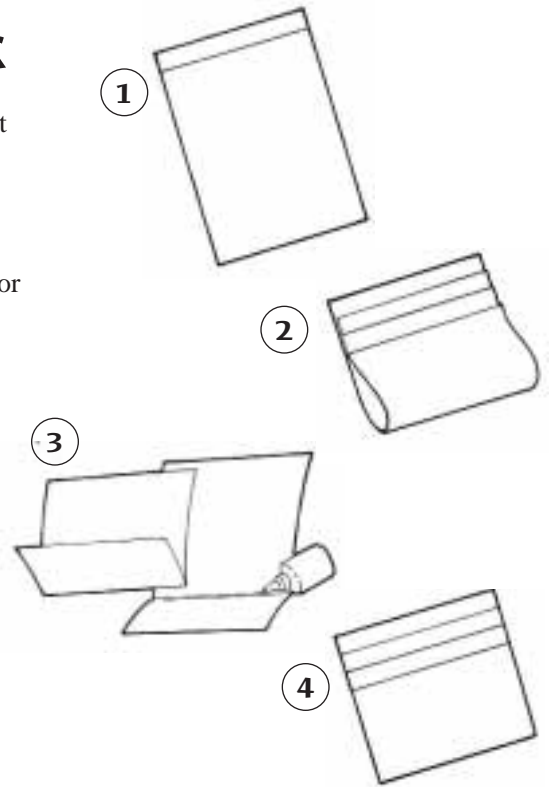

When using more than two sheets of paper, make the tabs smaller than an inch.

# Four-Tab Book

1. Fold a sheet of  $8\frac{1}{2}$ "  $\times$  11" paper in half like a *hot dog*.
2. Fold this long rectangle in half like a *hamburger*.
3. Fold both ends back to touch the *mountain top* or fold it like an *accordion*.
4. On the side with two *valleys* and one *mountain top*, make vertical cuts through one thickness of paper, forming four tabs.

Use this book for data occurring in fours. For example: the four steps in the order of operations.

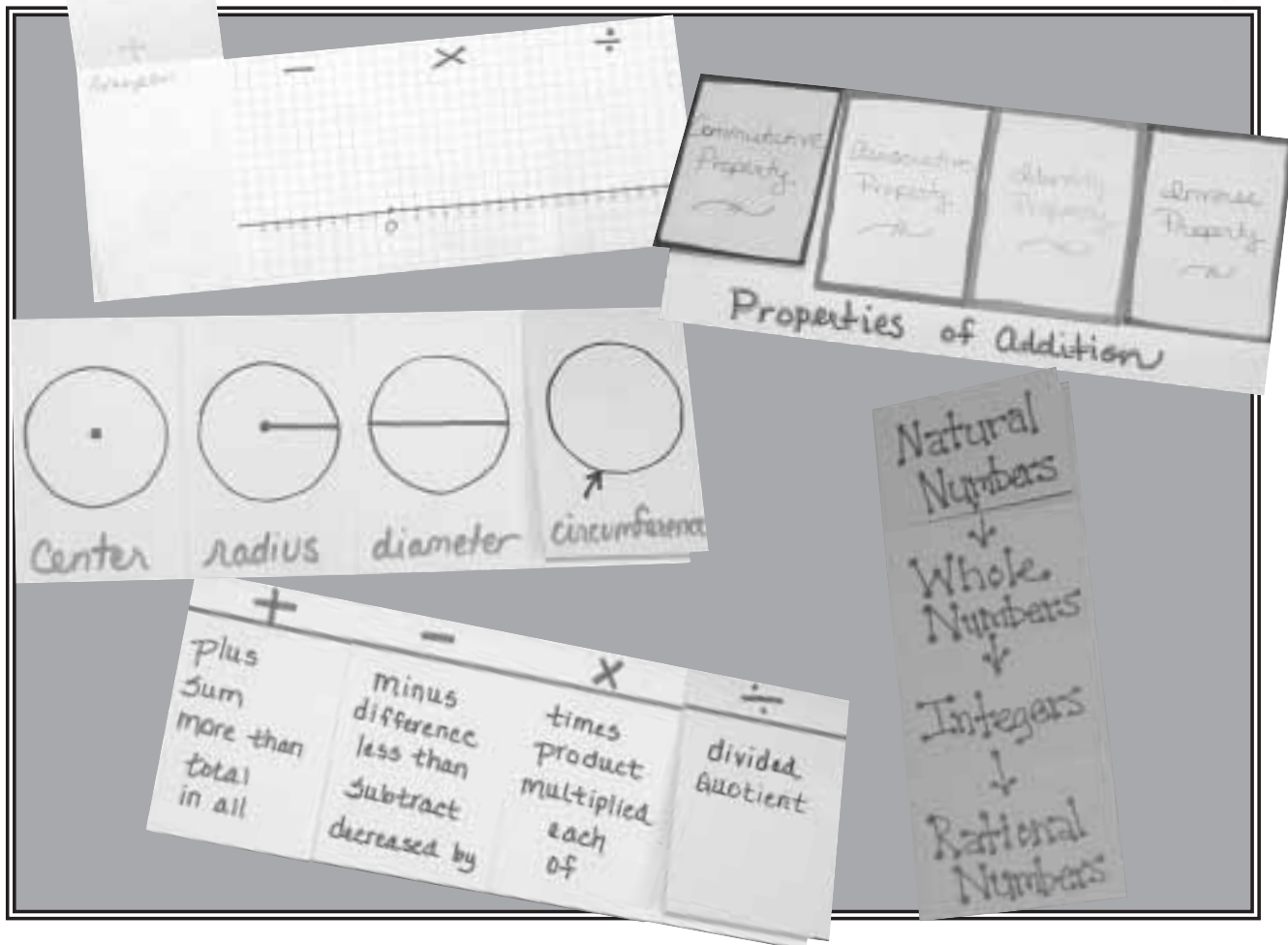
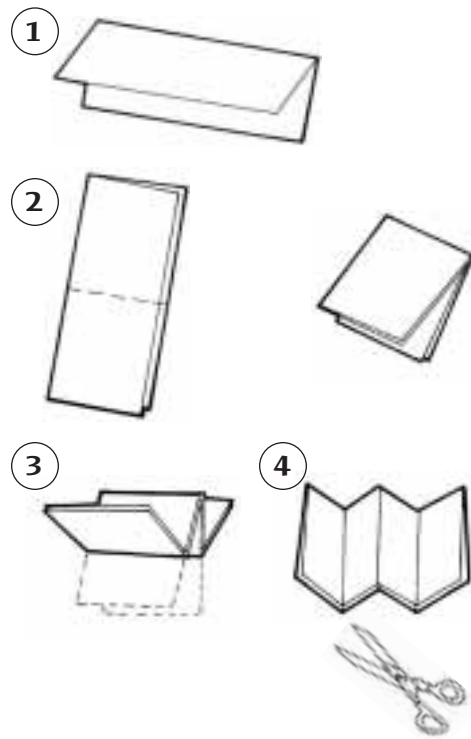

# Envelope Fold

1. Fold a sheet of  $8\frac{1}{2}'' \times 11''$  paper into a *taco* forming a square. Cut off the excess paper strip formed by the square.
2. Open the folded taco and refold it the opposite way forming another taco and an X fold pattern.
3. Open the *taco fold* and fold the corners toward the center point of the X forming a small square.
4. Trace this square on another sheet of paper. Cut and glue it to the inside of the envelope. Pictures can be placed under or on top of the tabs, or can be used to teach fractional parts.

Use this book for data occurring in fours. For example, four operations.

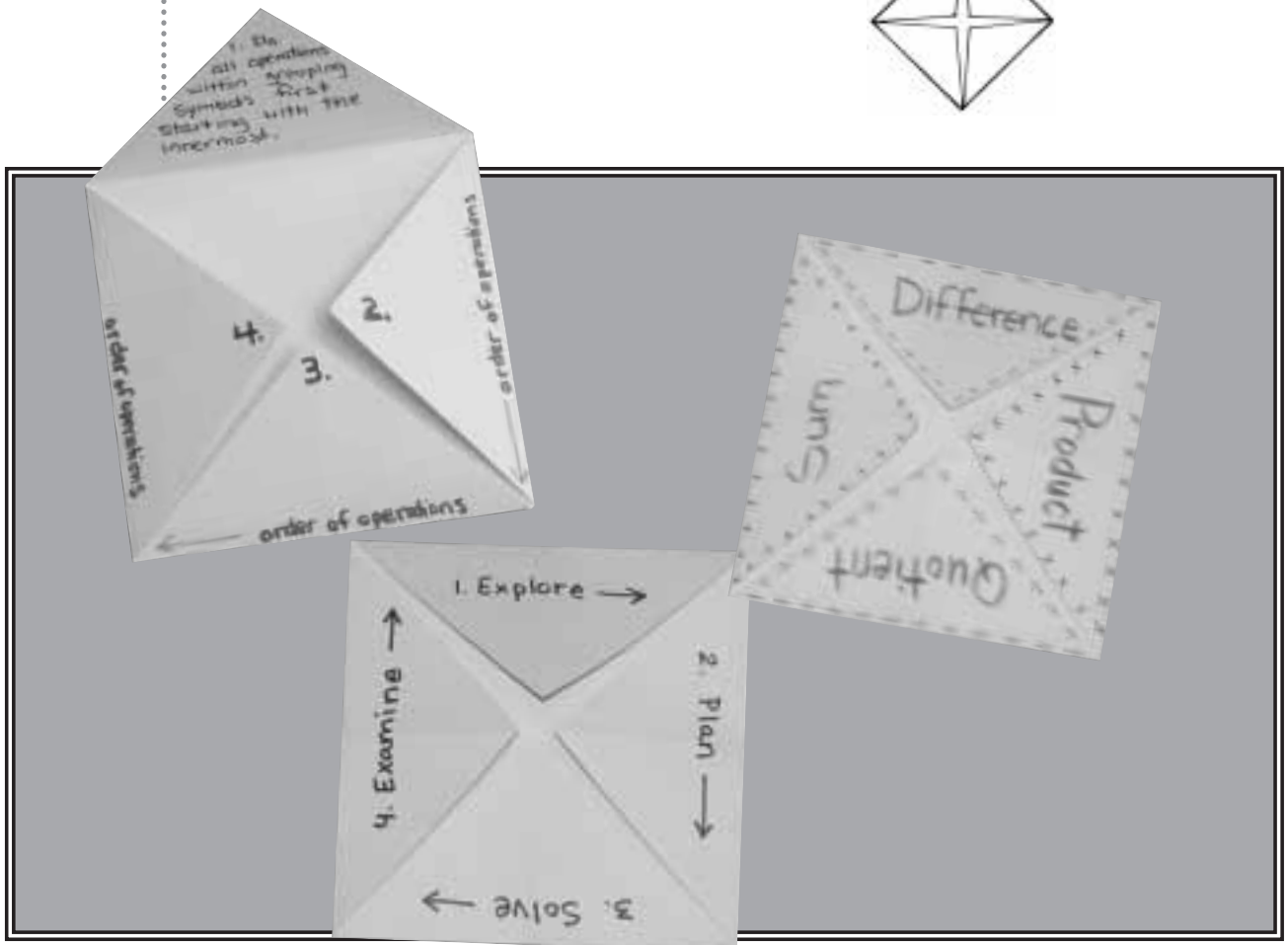
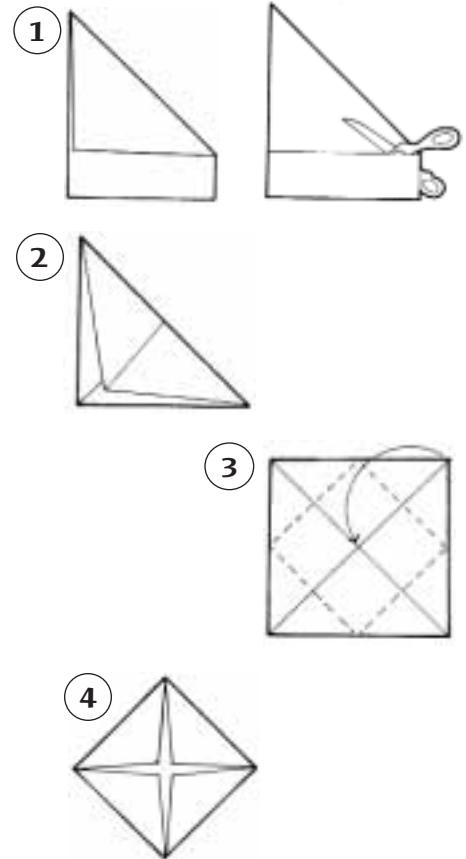

# Standing Cube

1. Use two sheets of the same size paper. Fold each like a *hamburger*. However, fold one side one half inch shorter than the other side. This will make a tab that extends out one half inch on one side.
2. Fold the long side over the short side of both sheets of paper, making tabs.
3. On one of the folded papers, place a small amount of glue along the the small folded tab, next to the *valley* but not in it.
4. Place the non-folded edge of the second sheet of paper square into the *valley* and fold the glue-covered tab over this sheet of paper. Press flat until the glue holds. Repeat with the other side.
5. Allow the glue to dry completely before continuing. After the glue has dried, the cube can be collapsed flat to allow students to work at their desks. The cube can also be folded into fourths for easier storage, or for moving it to a display area.

Use with data occurring in fours or make it into a project. Make a small display cube using  $8\frac{1}{2}'' \times 11''$  paper. Use  $11'' \times 17''$  paper to make large project cubes that you can glue other books onto for display. Notebook paper, photocopied sheets, magazine pictures, and current events also can be displayed on the large cube.

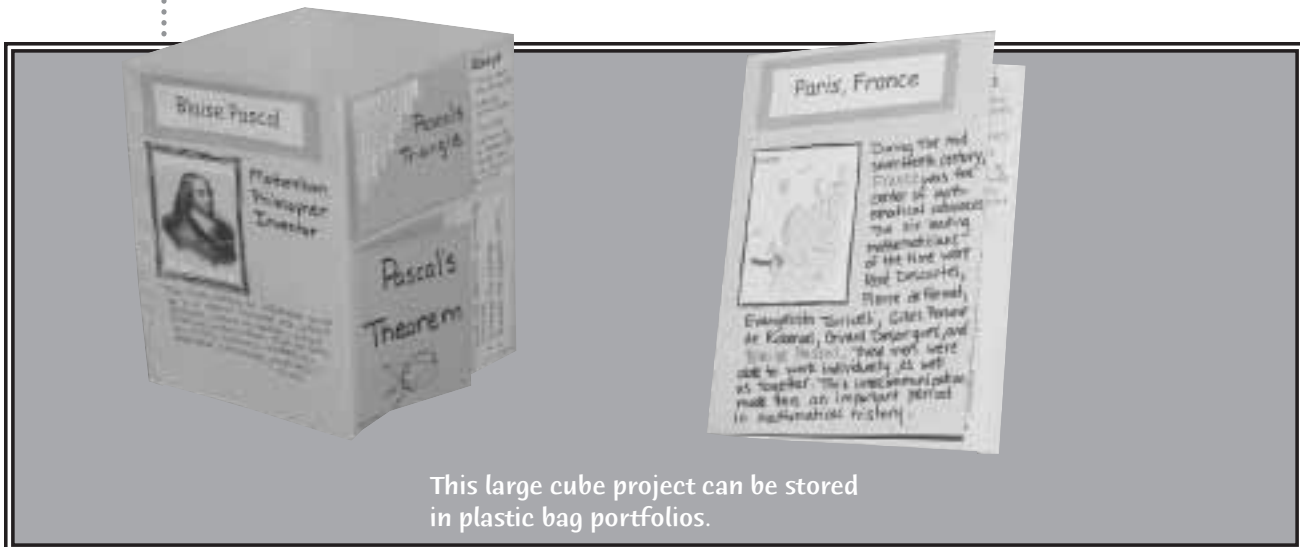
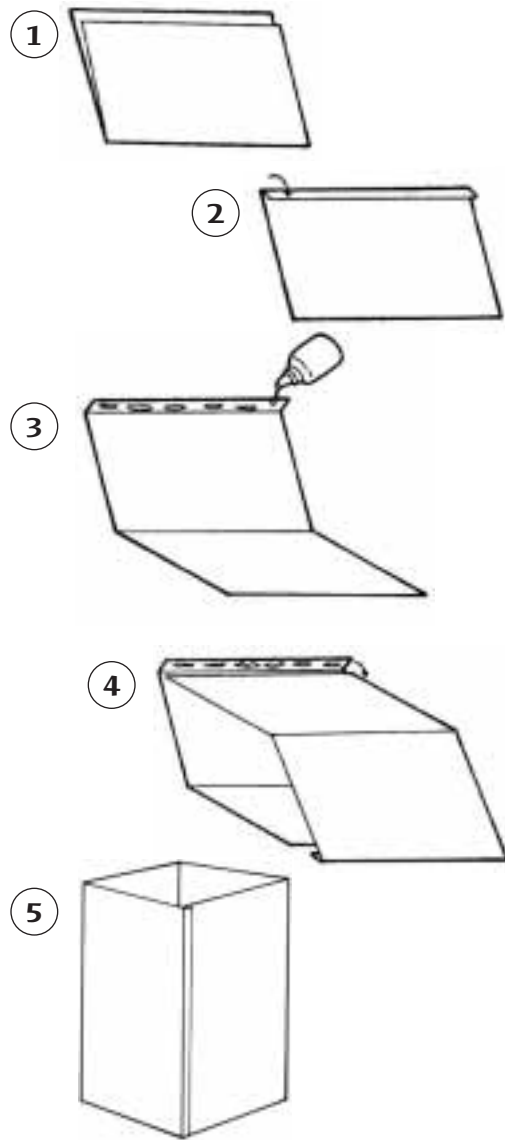

This large cube project can be stored in plastic bag portfolios.

# Four-Door Book

1. Make a *shutter fold* using 11" × 17" or 12" × 18" paper.
2. Fold the *shutter fold* in half like a *hamburger*. Crease well.
3. Open the project and cut along the two inside *valley folds*.
4. These cuts will form four doors on the inside of the project.

Use this fold for data occurring in fours. When folded in half like a *hamburger*, a finished *four-door book* can be glued inside a large (11" × 17") *shutter fold* as part of a larger project.

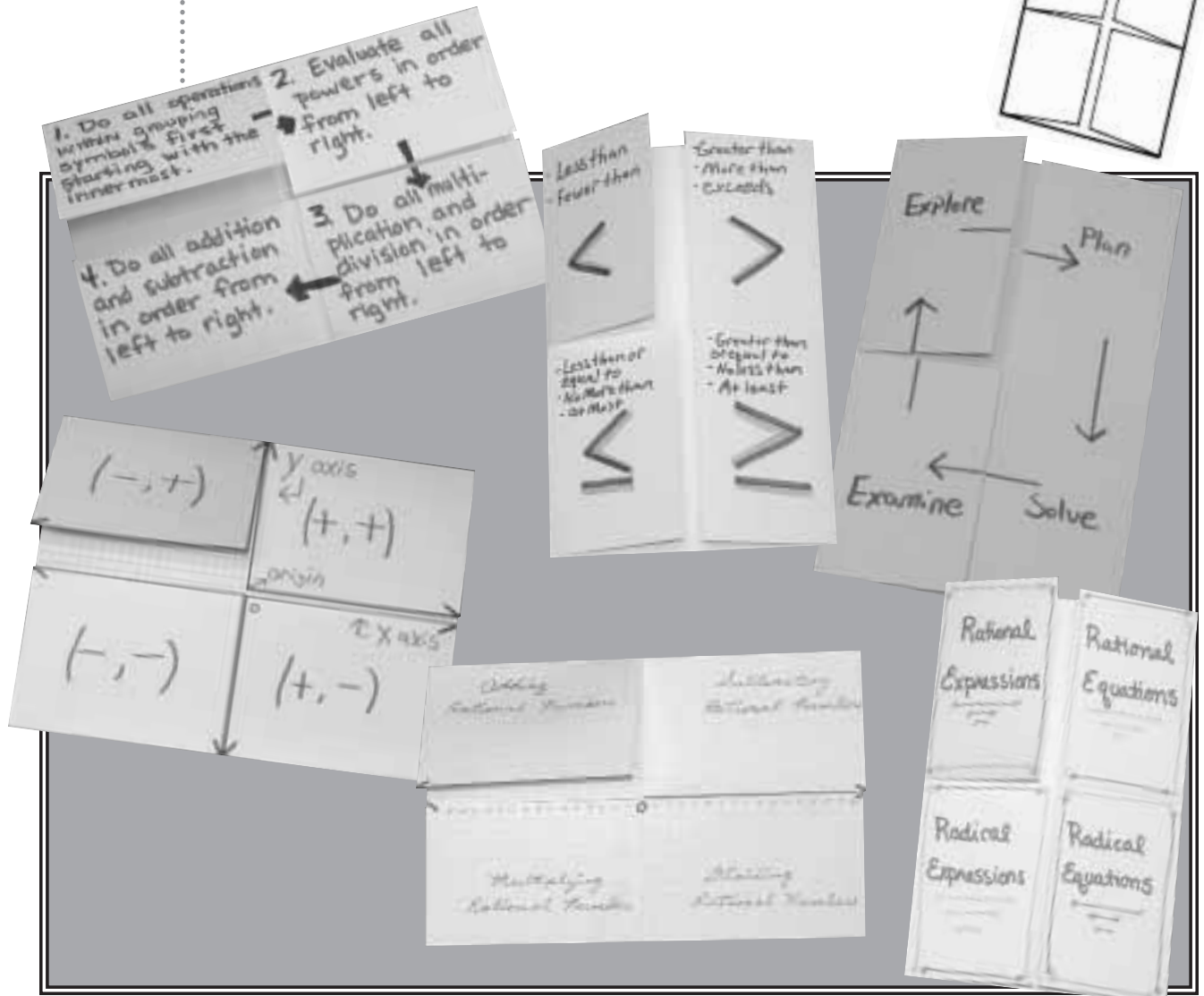
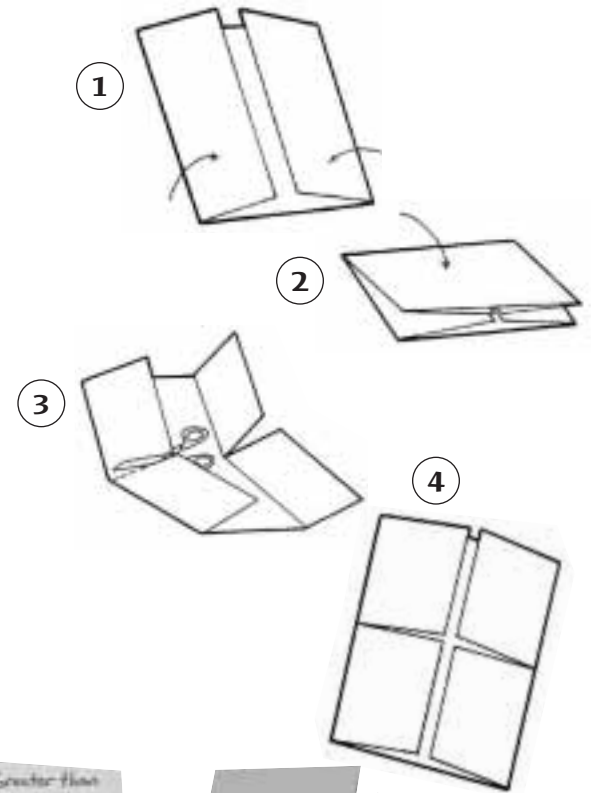

# Top-Tab Book

1. Fold a sheet of  $8\frac{1}{2}'' \times 11''$  paper in half like a *hamburger*. Cut the center fold, forming two half sheets.
2. Fold one of the half sheets four times. Begin by folding in half like a *hamburger*, fold again like a *hamburger*, and finally again like a *hamburger*. This folding has formed your pattern of four rows and four columns, or 16 small squares.
3. Fold two sheets of  $8\frac{1}{2}'' \times 11''$  paper in half like a *hamburger*. Cut the center folds, forming four half sheets.
4. Hold the pattern vertically and place on a half sheet of paper under the pattern. Cut the bottom right hand square out of both sheets. Set this first page aside.
5. Take a second half sheet of paper and place it under the pattern. Cut the first and second right hand squares out of both sheets. Place the second page on top of the first page.

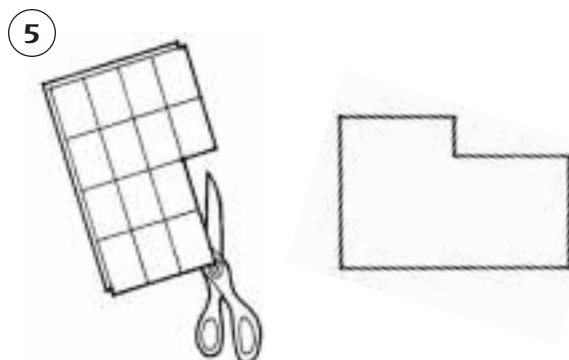
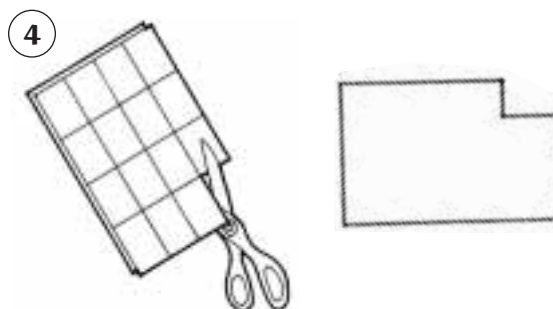
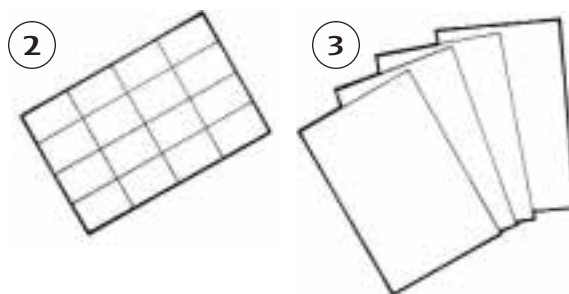
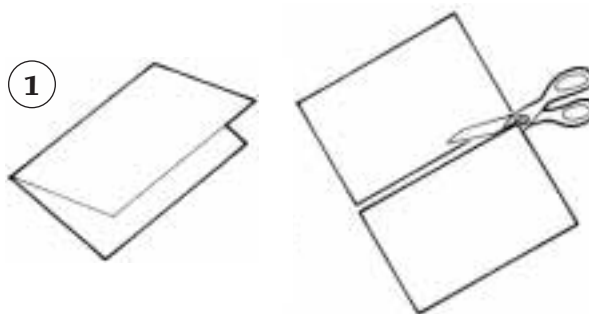



6. Take a third half sheet of paper and place it under the pattern. Cut the first, second, and third right hand squares out of both sheets. Place this third page on top of the second page.
7. Place the fourth, uncut half sheet of paper behind the three cut out sheets, leaving four aligned tabs across the top of the book. Staple several times on the left side. You can also place glue along the left paper edges, and stack them together. The glued spine is very strong.
8. Cut a final half sheet of paper with no tabs and staple along the left side to form a cover.

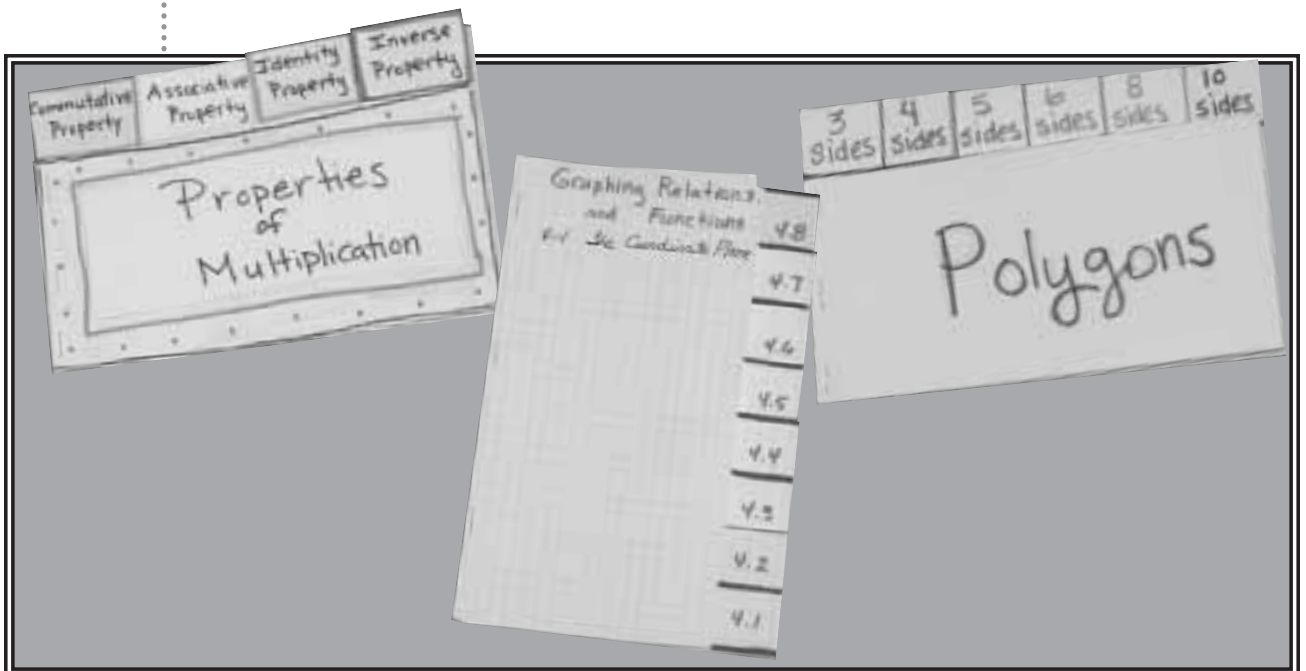
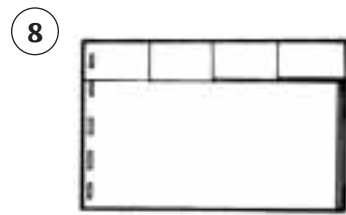
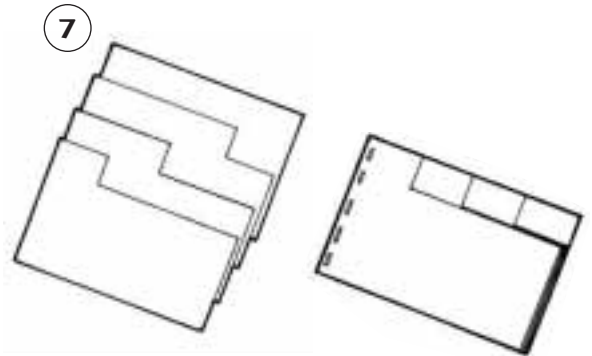
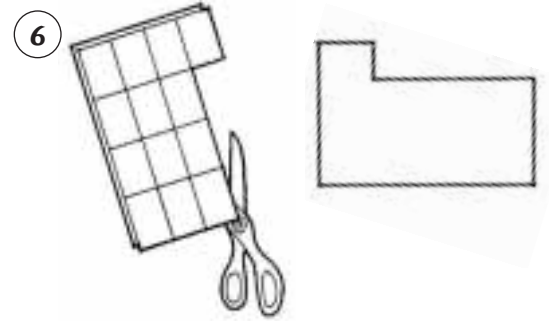

# Accordion Book

**NOTE:** Steps 1 and 2 should be done only if paper is too large to begin with.

1. Fold the selected paper into *hamburgers*.
2. Cut the paper in half along the fold lines.
3. Fold each section of paper into *hamburgers*. However, fold one side one half inch shorter than the other side. This will form a tab that is one half inch long.
4. Fold this tab forward over the shorter side, and then fold it back away from the shorter piece of paper. In other words, fold it the opposite way.
5. Glue together to form an *accordion* by gluing a straight edge of one section into the *valley* of another section.

**NOTE:** Stand the sections on end to form an accordion to help students visualize how to glue them together. (See illustration.)

Always place the extra tab at the back of the book so you can add more pages later.

Use this book for number lines, timelines, student projects that grow, sequencing events or data, and more.

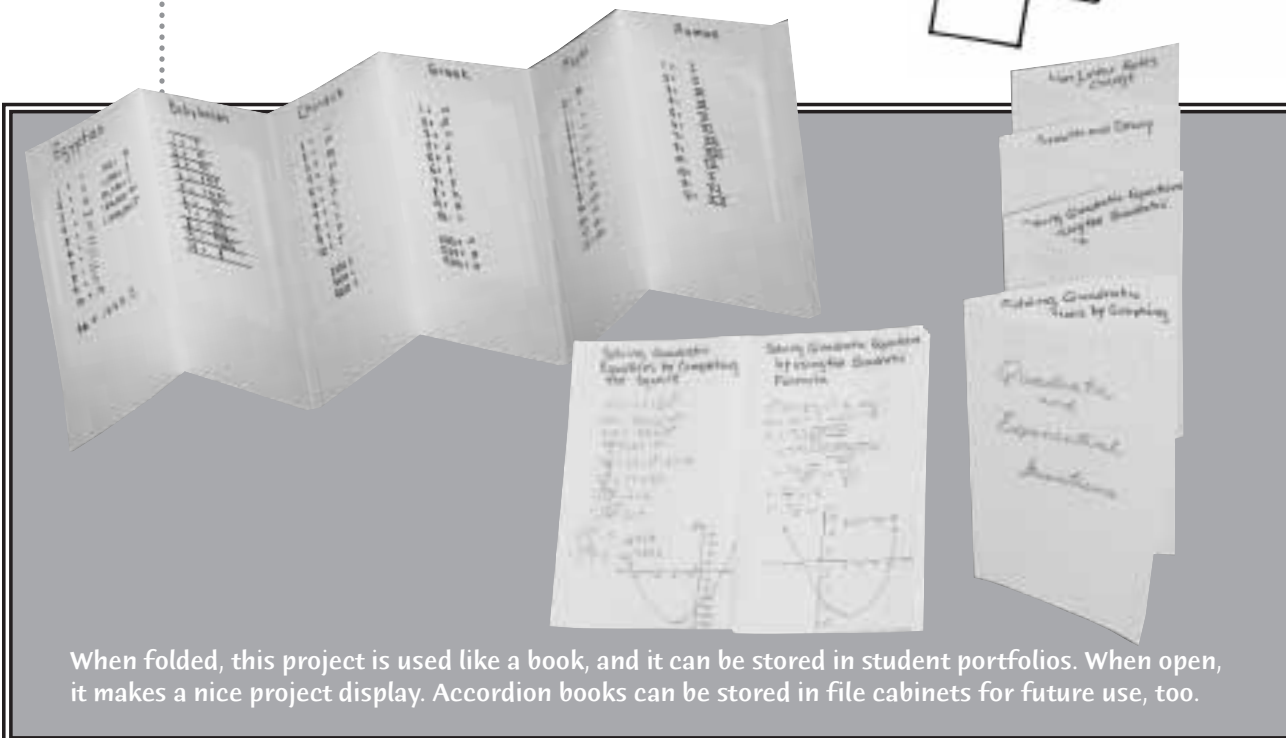
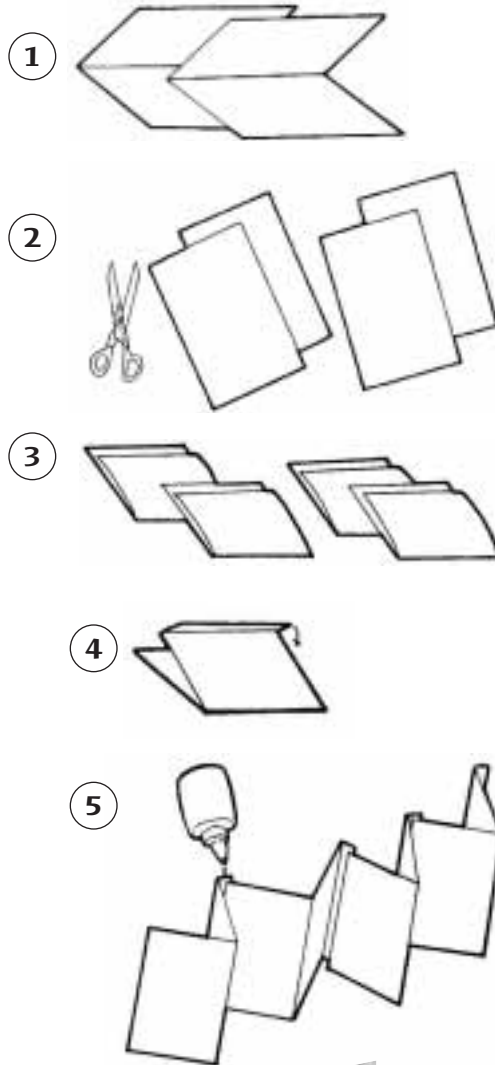

When folded, this project is used like a book, and it can be stored in student portfolios. When open, it makes a nice project display. Accordion books can be stored in file cabinets for future use, too.

# Pop-Up Book

1. Fold a sheet of  $8\frac{1}{2}'' \times 11''$  paper in half like a *hamburger*.
2. Beginning at the fold, or *mountain top*, cut one or more tabs.
3. Fold the tabs back and forth several times until there is a good fold line formed.
4. Partially open the *hamburger* fold and push the tabs through to the inside.
5. With one small dot of glue, glue figures for the *pop-up book* to the front of each tab. Allow the glue to dry before going on to the next step.
6. Make a cover for the book by folding another sheet of paper in half like a *hamburger*. Place glue around the outside edges of the *pop-up book* and firmly press inside the *hamburger* cover.

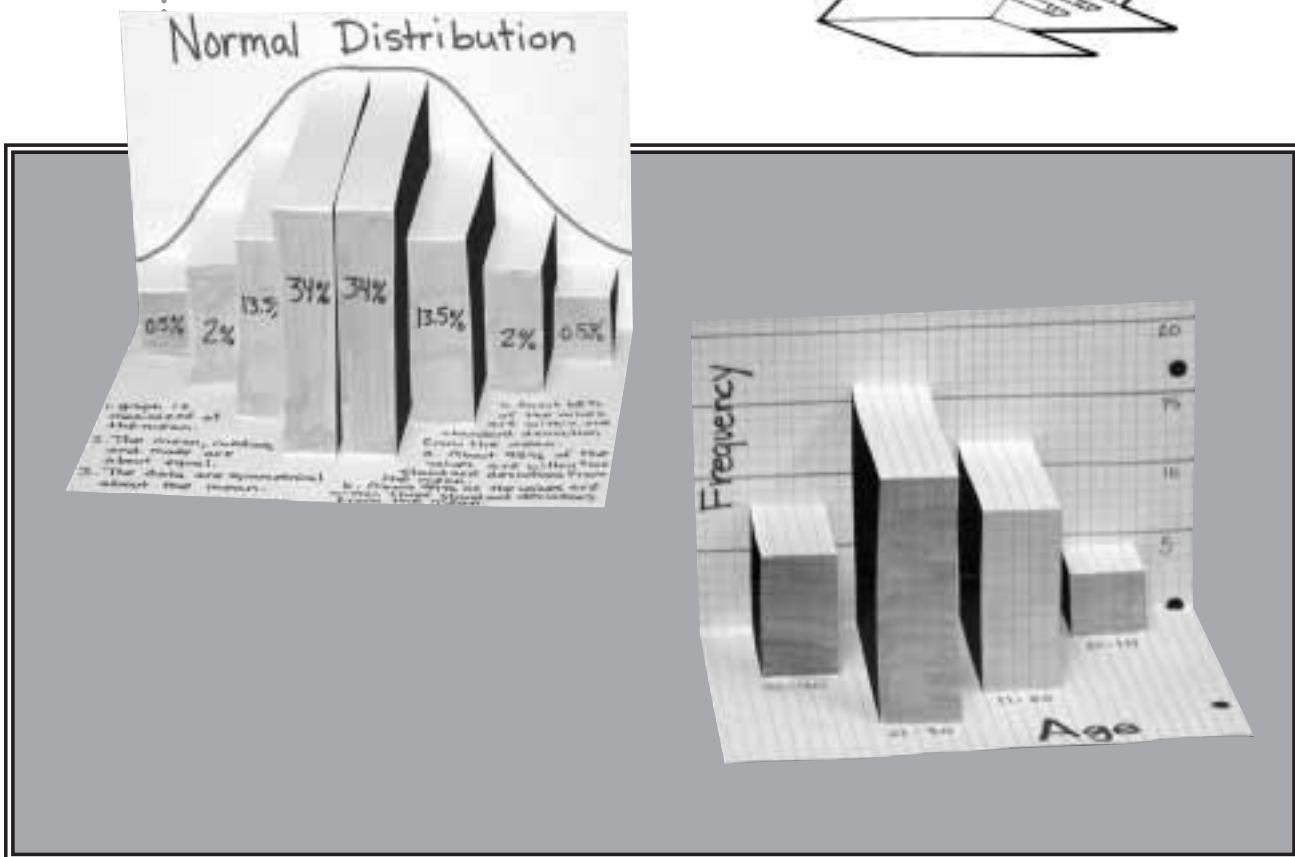
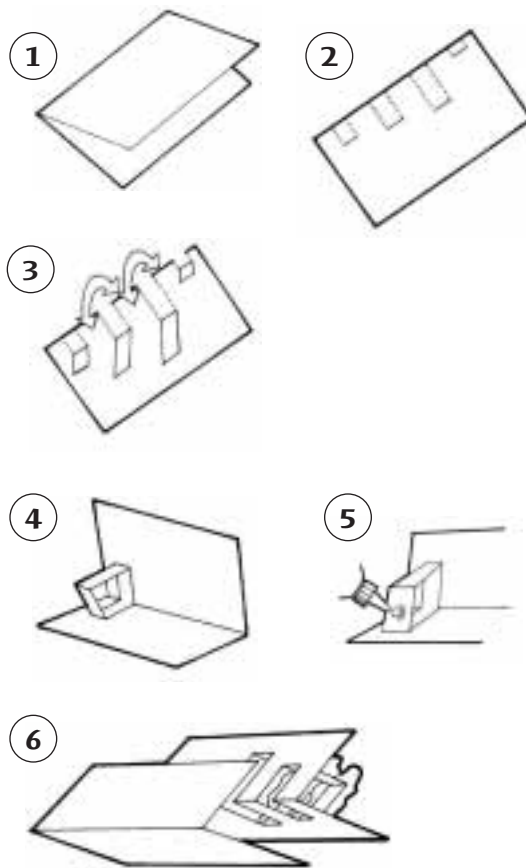

# Folding into Fifths

1. Fold a sheet of paper in half like a *hotdog* or *hamburger* for a five-tab book, or leave open for a folded table or chart.
2. Fold the paper so that one third is exposed and two thirds are covered.
3. Fold the two thirds section in half.
4. Fold the one third section backward to form fifths. The paper will be divided into fifths when opened.

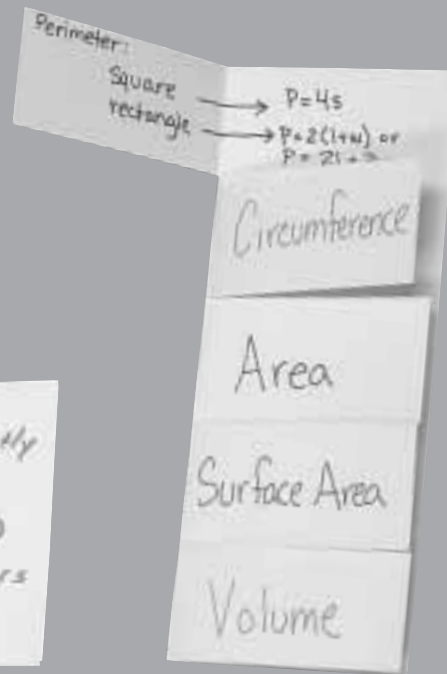
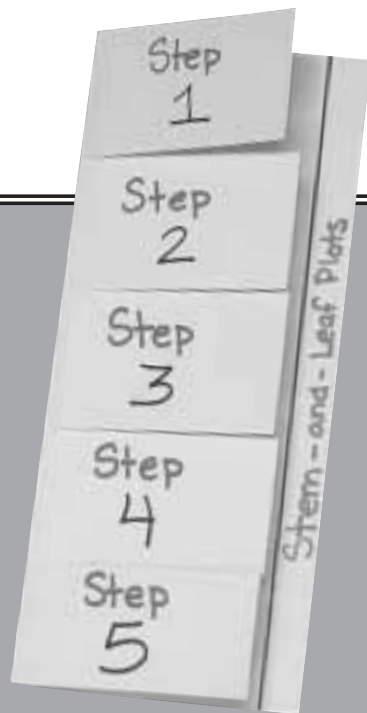
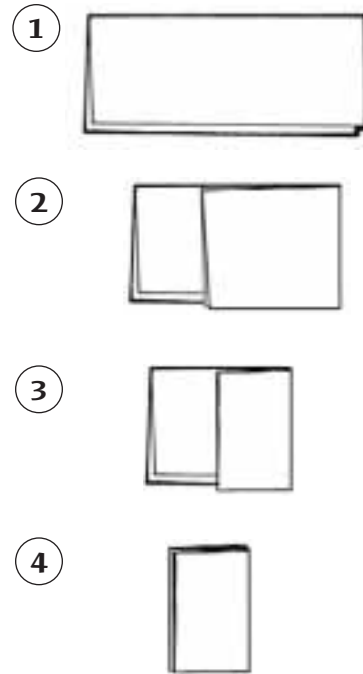

# Folded Table, Chart, or Graph

1. Fold the number of vertical columns needed to make the table or chart.
2. Fold the horizontal rows needed to make the table or chart.
3. Label the rows and columns.

*Remember:* Tables are organized along vertical and horizontal axes, while charts are organized along one axis, either horizontal or vertical.

Table



Chart

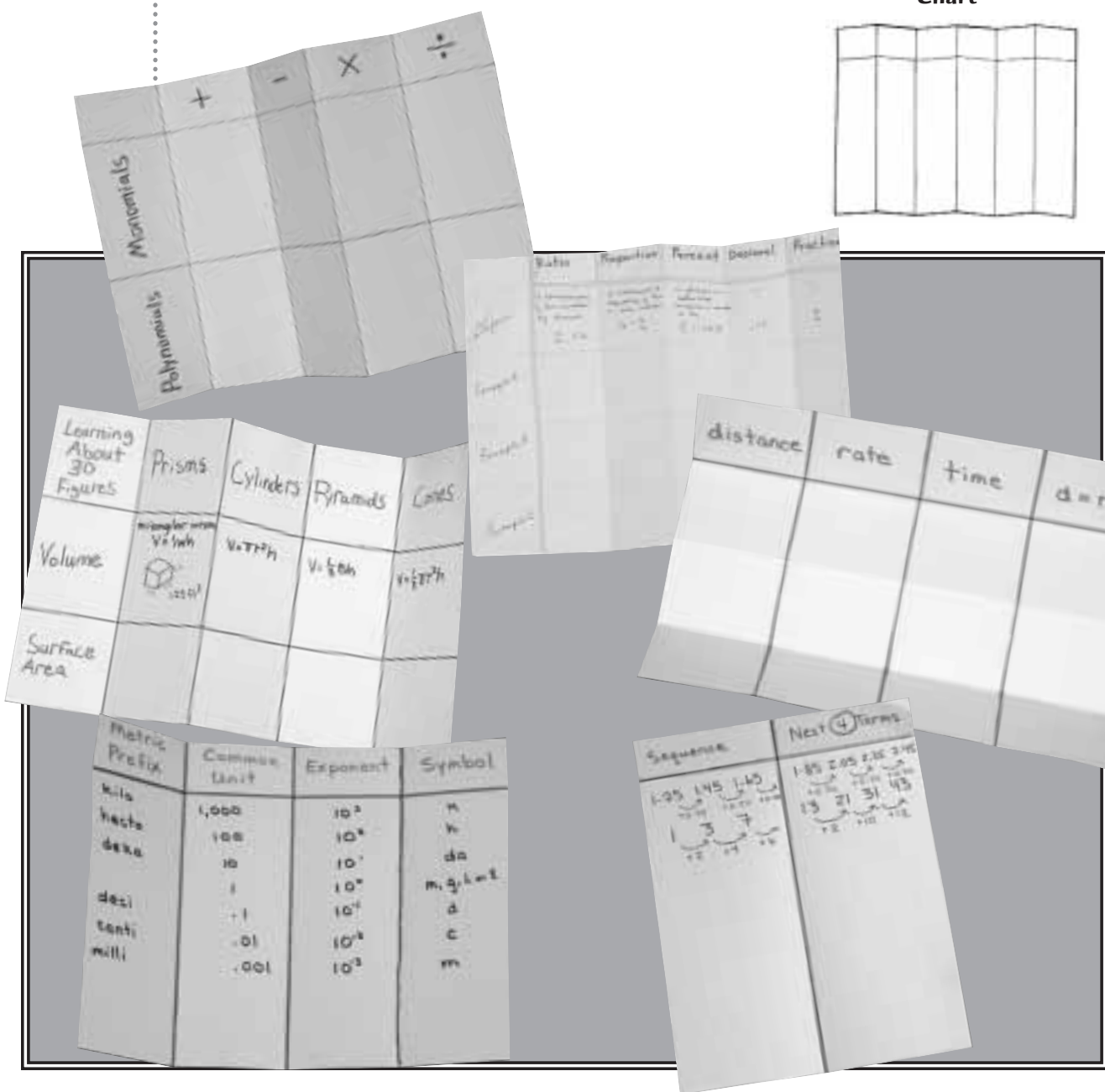
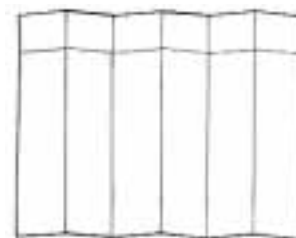

# Folding a Circle into Tenths

1. Fold a paper circle in half.
2. Fold the half circle so that one third is exposed and two thirds are covered.
3. Fold the one third (single thickness) backward to form a fold line.
4. Fold the two thirds section in half.
5. The half circle will be divided into fifths. When opened, the circle will be divided into tenths.

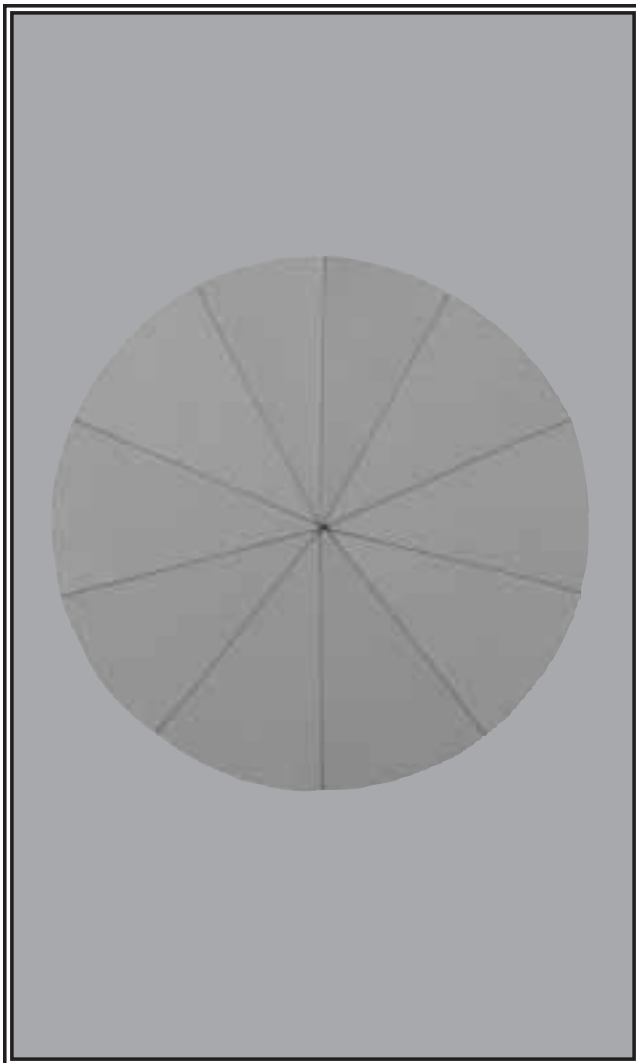
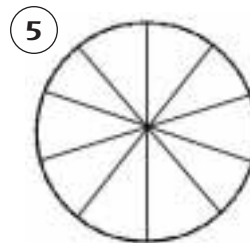
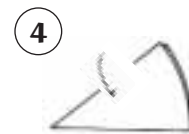
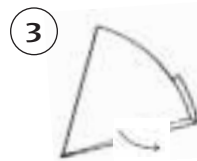
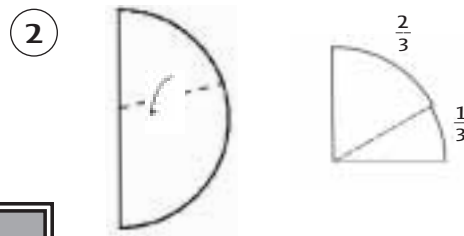
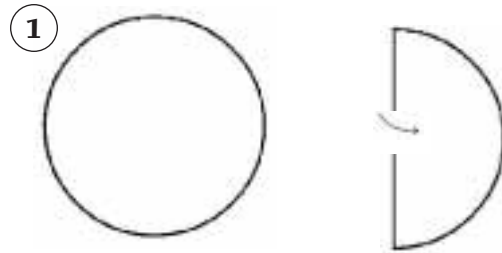

**NOTE:** Paper squares and rectangles are folded into tenths the same way. Fold them so that one third is exposed and two thirds is covered. Continue with steps 3 and 4.

# Circle Graph

1. Cut out two circles using a pattern.
2. Fold one of the circles in half on each axis, forming fourths. Cut along one of the fold lines (the radius) to the middle of each circle. Flatten the circle.
3. Slip the two circles together along the cuts until they overlap completely.
4. Spin one of the circles while holding the other stationary. Estimate how much of each of the two (or you can add more) circles should be exposed to illustrate given percents or fractional parts of data. Add circles to represent more than two percents.

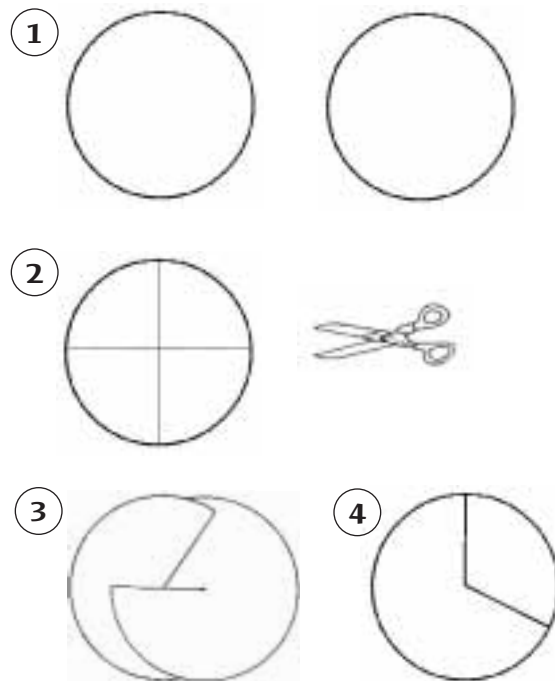

Use large circle graphs on bulletin boards.

Oxygen	47%	$47\% \times 360 = 169.2$
Silicon	28%	$28\% \times 360 = 100.8$
Other	12%	$12\% \times 360 = 43.2$
Aluminum	8%	$8\% \times 360 = 28.8$
Iron	5%	$5\% \times 360 = 18$

Use small circle graphs in student projects or on the front of tab books.

# Concept-Map Book

1. Fold a sheet of paper along the long or short axis, leaving a two-inch tab uncovered along the top.
2. Fold in half or in thirds.
3. Unfold and cut along the two or three inside fold lines.

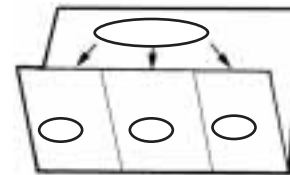
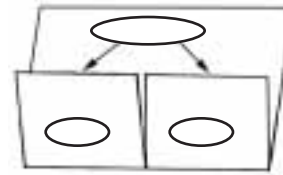

**PROBABILITY**

- Outcomes
- Permutations
- Combinations
- Compound Events

**EQUATIONS**

- Equivalent
- Not Equivalent

**Additive Inverse Property**

- Arithmetic  
 $5 + (-5) = 0$
- Algebra  
 $x + (-x) = 0$

**Decimals**

- terminating
- repeating

**Trigonometric Ratios**

- Sine
- Cosine
- Tangent

**Problem Solving**

- Deductive Reasoning
- Inductive Reasoning



# Vocabulary Book

1. Fold a sheet of notebook paper in half like a hotdog.
2. On one side, cut every third line. This usually results in ten tabs.
3. Label the tabs.



Use to take notes and record data.

Leave the notebook holes uncovered and the Foldable can be stored in a notebook.

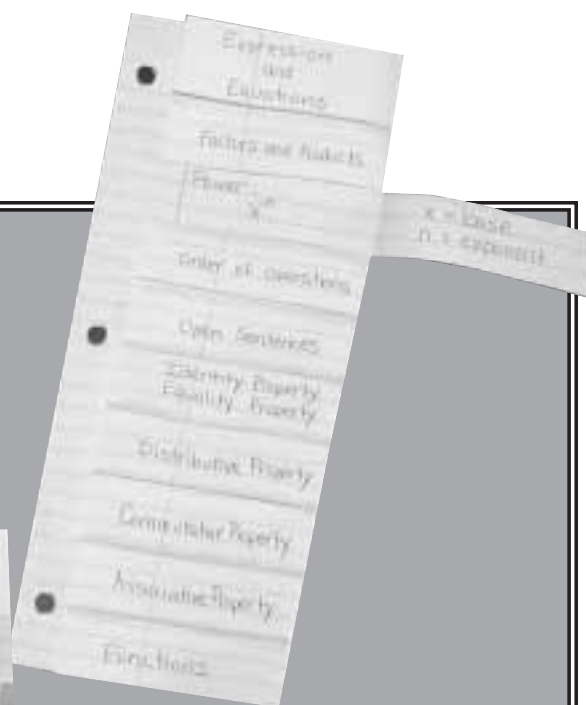

Use for vocabulary books.



Use for recording student questions and answers.

# Billboard Project

1. Fold all pieces of the same size of paper in half like *hamburgers*.
2. Place a line of glue at the top and bottom of one side of each folded billboard section and glue them edge-to-edge on a background paper or project board. If glued correctly, all doors will open from right to left.
3. Pictures, dates, words, etc., go on the front of each billboard section. When opened, writing or drawings can be seen on the inside left of each section. The base, or the part glued to the background, is perfect for more in-depth information or definitions.

Use for timelines or sequencing data and number lines.

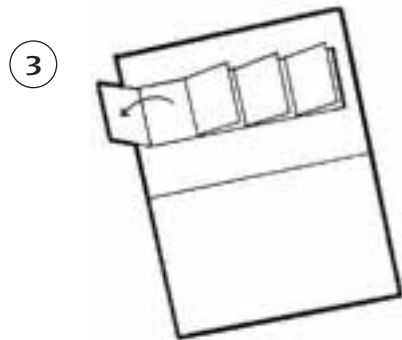
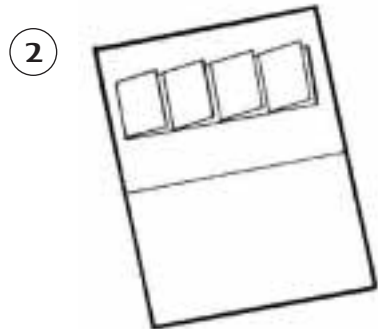

# Sentence-Strip Holder

1. Fold a sheet of  $8\frac{1}{2}$ "  $\times$  11" paper in half like a *hamburger*.
2. Open the *hamburger* and fold the two outer edges toward the *valley*. This forms a *shutter fold*.
3. Fold one of the inside edges of the shutter back to the outside fold. This fold forms a floppy "L".
4. Glue the floppy L-tab down to the base so that it forms a strong, straight L-tab.
5. Glue the other shutter side to the front of this L-tab. This forms a tent that is the backboard for the flashcards or student work to be displayed.

Fold the edge of the L-tab up one quarter to one half to form a lip that will keep the student work from slipping off the holder.

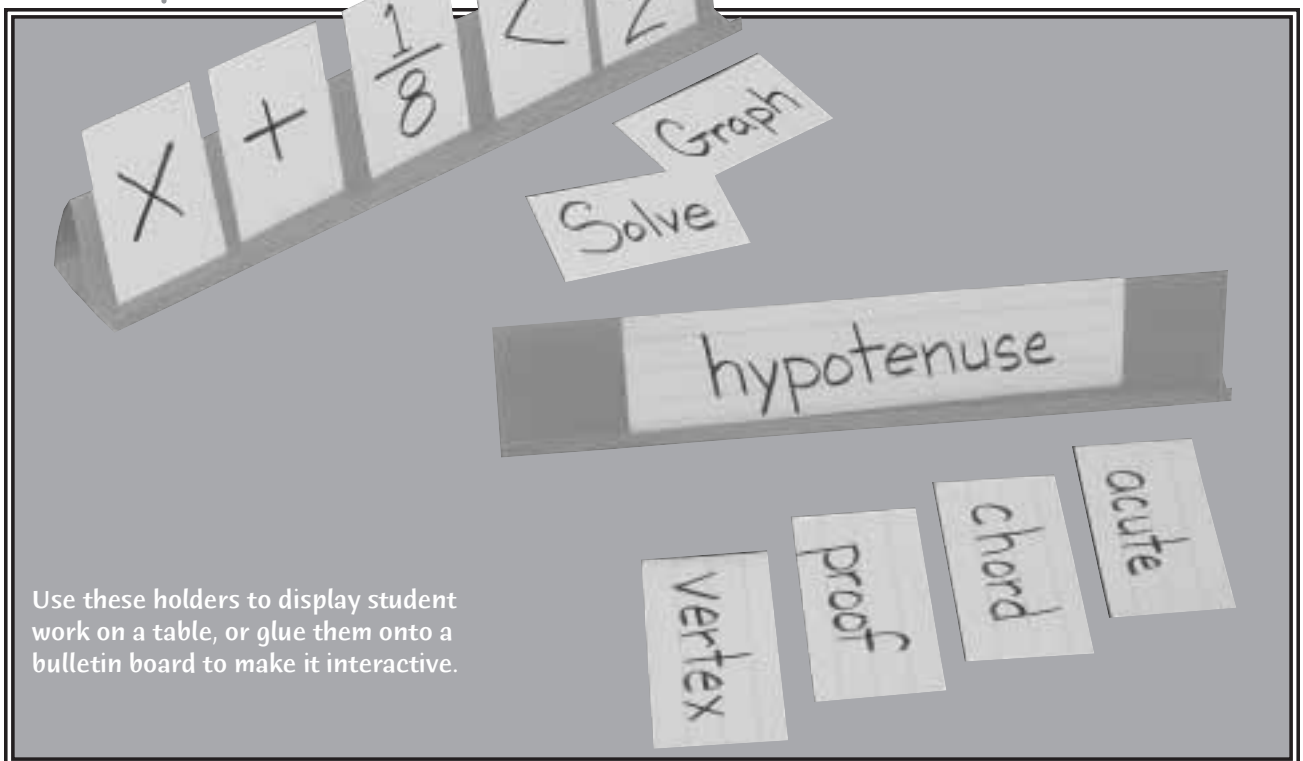
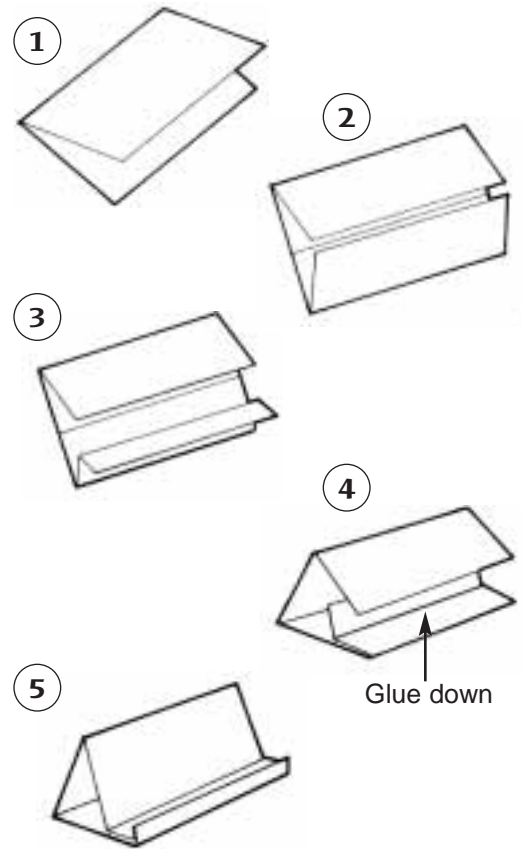

Use these holders to display student work on a table, or glue them onto a bulletin board to make it interactive.

# Sentence Strips

1. Take two sheets of  $8\frac{1}{2}'' \times 11''$  paper and fold into *hamburgers*. Cut along the fold lines making four half sheets. (Use as many half sheets as necessary for additional pages to your book.)
2. Fold each sheet in half like a *hotdog*.
3. Place the folds side-by-side and staple them together on the left side.
4. One inch from the stapled edge, cut the front page of each folded section up to the mountain top. These cuts form flaps that can be raised or lowered.

To make a half-cover, use a sheet of construction paper one inch longer than the book. Glue the back of the last sheet to the construction paper strip leaving one inch, on the left side, to fold over and cover the original staples. Staple this half-cover in place.

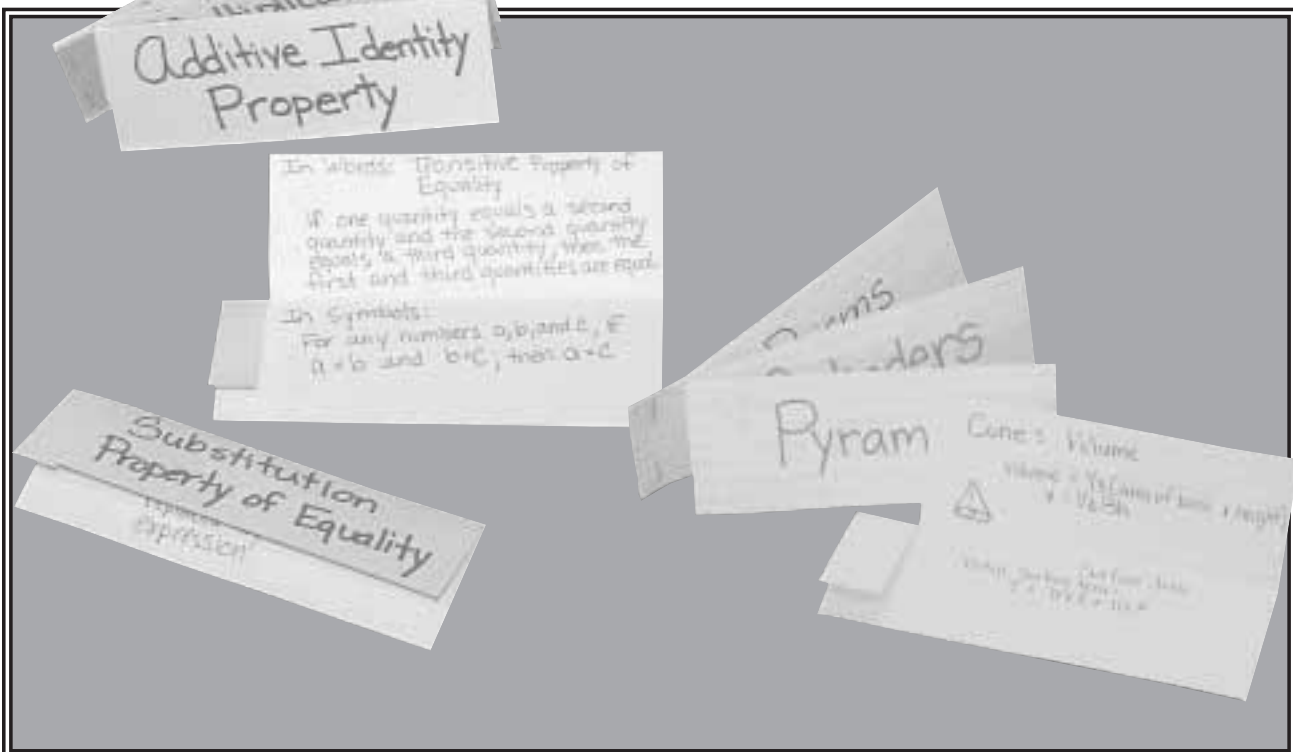
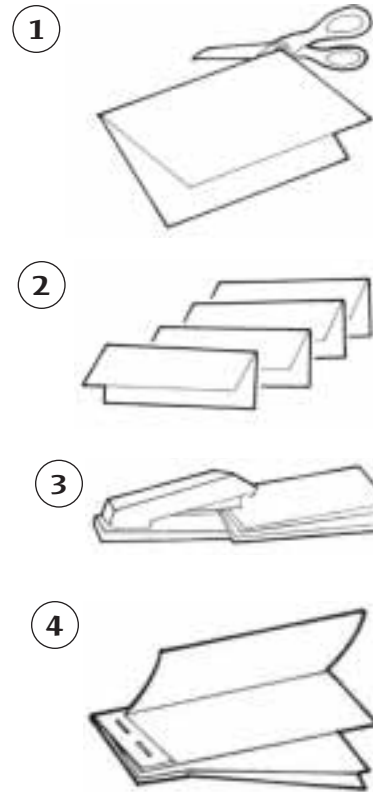

# Whole Numbers

Skill	Activity Suggestion	Foldable Parts
define	whole numbers as the counting numbers ( 0, 1, 2, 3. ...) and list examples	2
explain	why fractions such as $\frac{3}{3}$ , $\frac{4}{4}$ , and $\frac{8}{8}$ are whole numbers	1
find	10 examples of equivalent whole numbers: $3, \frac{9}{3}$	10
describe	the two basic operations that can be performed on whole numbers: addition (combines individual numbers) and multiplication (combines groups of numbers) subtraction and division as the inverse operations of addition and multiplication	2
explain and use	the Commutative Property of Addition and the Commutative Property of Multiplication. the Associative Property of Addition and the Associative Property of Multiplication	4
outline	the Distributive Property, also called the Distributive Property of Multiplication over Addition	1
differentiate between	the Commutative Property, Associative Property, and the Distributive Property	3
define	sum, difference, product, and quotient as they relate to whole numbers	4
determine	if subtraction and division are associative (neither are) and explain your answer	2
list and describe	the order in which operations should be performed: multiply and/or divide then add and/or subtract	2
compare and contrast	two types of whole numbers: primes and composites	2
note and	every whole number is either prime or composite explain except for 0 and 1 which are neither	1
give	examples of prime factors for six whole numbers	6
reduce	given fractions to see what whole number they represent: $\frac{12}{4}, \frac{18}{9}$	any number
determine	whole numbers are greater than, less than, or equal to other whole numbers	3
round	whether five whole numbers to the nearest ten, nearest hundred, nearest thousand	5
demonstrate	three ways whole numbers can be written	3
use	whole numbers to solve real-world problems	any number
Venn diagram	characteristics of prime numbers, composite numbers, and both	3

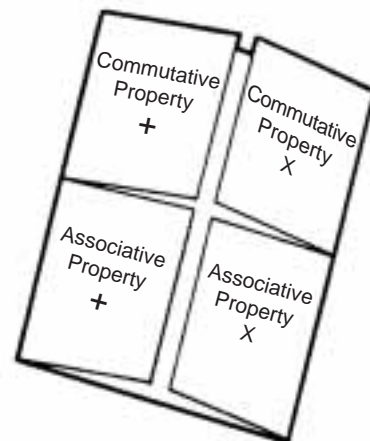

Four-Door Book

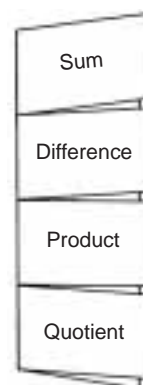

Four-Tab book

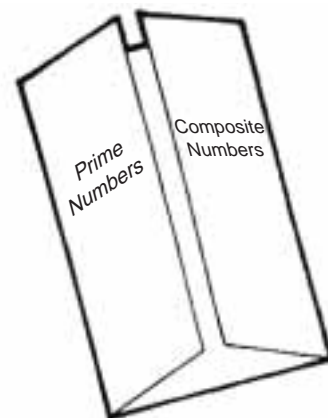

Shutter Fold

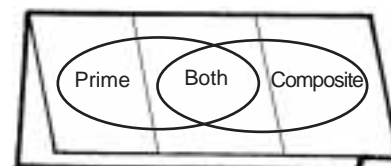
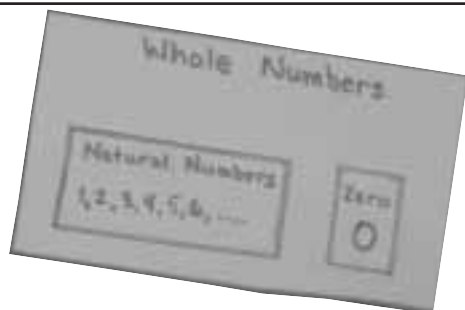

Three-Tab Venn diagram

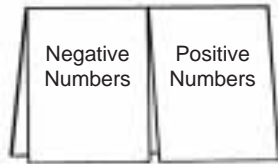

Two-Tab Book



Four-Tab Book

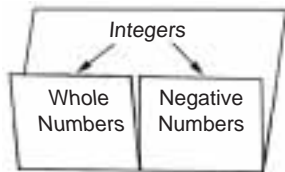

Two-Tab Concept Map

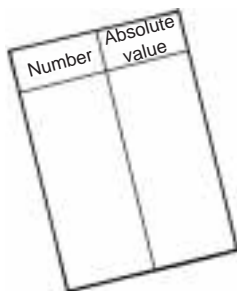

Folded Chart



Number Line

# Integers

Skill	Activity Suggestion	Foldable Parts
define	integers as the set of whole numbers and their opposites, or negative numbers (... -3, -2, -1, 0, 1, 2, 3...)	1
differentiate between	positive and negative numbers	2
list	examples of positive and negative integers	2
explain	in your own words why you think zero is neither positive nor negative, but part of the set of integers	1
show	how the set of integers might be written {... -3, -2, -1, 0, 1, 2, 3, ...} and explain the use of ellipses	2
describe	four examples of the use of negative numbers in the real world: temperature, balancing account books, reporting weight loss, distance lost in a game or sport	4
define	absolute value as the number of units a number is from 0 on a number line	1
write	the definition of absolute value in words and symbols	2
find	the absolute value of given expressions	any number
explain	why absolute value can never be less than 0	1
describe	absolute value in terms of distance and give examples	2
graph	given integers on a number line	any number
	two points on a number line so that the coordinates of both have an absolute value of a given number	any number
write	inequalities using integers	any number
sequence	given integers from greatest to least, or from least to greatest	any number
state	which integers have the greater absolute value	any number
describe	how to determine if one integer is less than or greater than another integer	2
design	a concept map that shows integers as the union of whole numbers and their opposites	2
make	a number line for whole numbers and integers	1

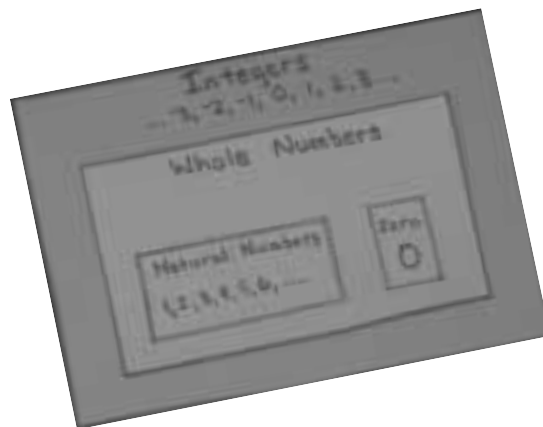

## Integers: Adding and Subtracting

Skill	Activity Suggestion	Foldable Parts
describe	how to add integers with the same sign	1
use	a number line and show how to add integers with the same sign	2
explain	how to add integers with different signs	1
use	a number line and show how to add integers with different signs	any number
compare and contrast	adding integers with the same and different signs	2
draw	a model that shows how to find the sum of two integers on a number line and describe your model	2
explain	how adding and subtracting are inverse operations that “undo” each other	2
use	a number line to show what happens when you add opposites like $-9$ and $9$	any number
define	an integer and its opposite as additive inverses of each other	1
describe	additive inverse in words, numerically, and algebraically	3
explain	how to subtract integers using what you know about additive inverses	1
describe	how to subtract an integer in words, numerically, and algebraically	3
draw	a model that shows how to find $7 - (-2)$	1
simplify	expressions such as $15x - 18x$	any number

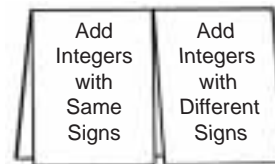

Two-Tab Book

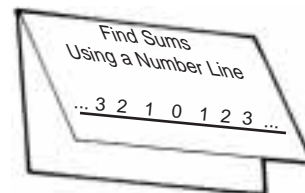

Half Book

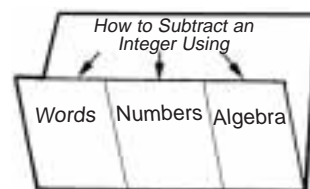

Three-Tab Concept Map

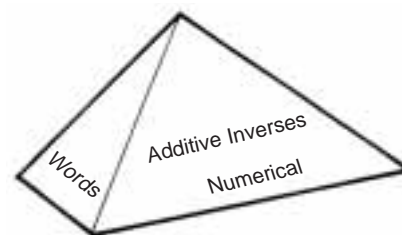

Pyramid Fold

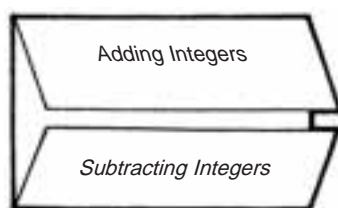

Shutter Fold

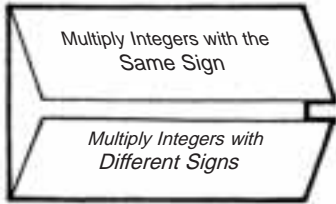

**Shutter Fold**

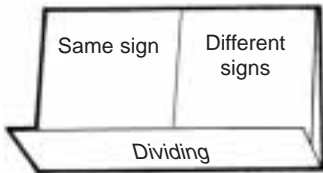

**Matchbook**

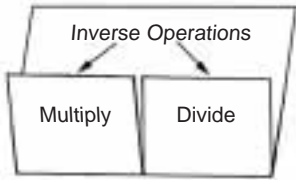

**Two-Tab Concept Map**

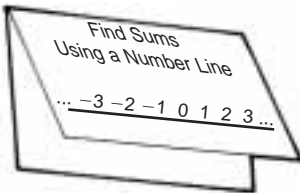

**Half Book**

## Integers: Multiplying and Dividing

Skill	Activity Suggestion	Foldable Parts
describe	how to multiply integers with the same sign	1
use	a number line to show and explain how to multiply integers with the same sign	any number
explain	how to multiply integers with different signs	1
use	a number line to show and explain how to multiply integers with different signs	2
compare and contrast	multiplying integers with the same and different signs	2
draw	a model that shows how to find the product of two integers on a number line and write about the process	2
review	how multiplying and dividing are inverse operations that “undo” each other	2
explain	how to divide integers with the same sign	1
demonstrate	how to divide integers with different signs	1
describe	how to divide integers with the same and different signs in words, numerically, and algebraically	3
find	similarities and differences between multiplying and dividing integers with the same signs and multiplying and dividing integers with different signs	4

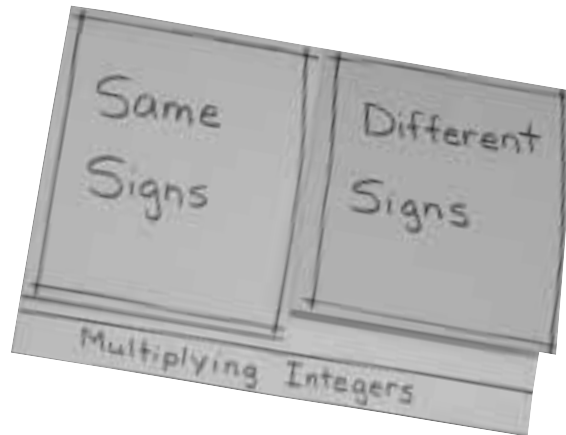



# Rational Numbers

Skill	Activity Suggestion	Foldable Parts
define	rational numbers as numbers that can be written as a ratio, or fraction where $a$ and $b$ are integers and $b$ is not equal to 0	1
explain	why whole numbers, integers, fractions, mixed numbers, terminating decimals, and repeating decimals are rational numbers	6
chart	and list examples of whole numbers, integers, fractions, terminating decimals, and repeating decimals	5
document	five rational numbers encountered in a day	5
rename	10 rational numbers	10
write	decimals as fractions and fractions as decimals	2
solve	equations using rational numbers	any number
design	a concept map for rational numbers. rational numbers: fractions, repeating and terminating decimals, integers, and whole numbers	5
estimate	sums of rational numbers	any number
find	sums of rational numbers	any number
solve	equations involving rational numbers	any number
	inequalities involving rational numbers	any number
explain	how adding and subtracting rational numbers follow the same principles as adding and subtracting integers	2
use	rational numbers to write three examples of the Commutative Property	3
	rational numbers to write three examples of the Associative Property	3
	rational numbers to write three examples of the Identity Property	3
	rational numbers to write three examples of the Inverse Property	3

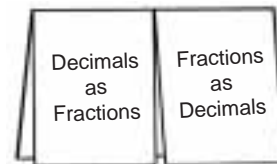

Two-Tab Book

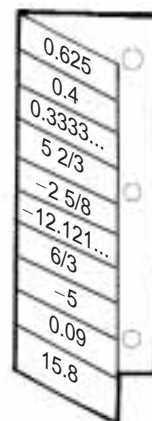

Vocabulary Book

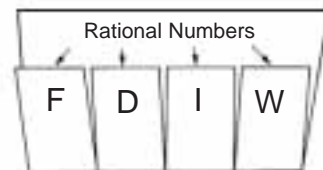

Concept Map

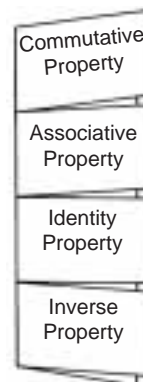
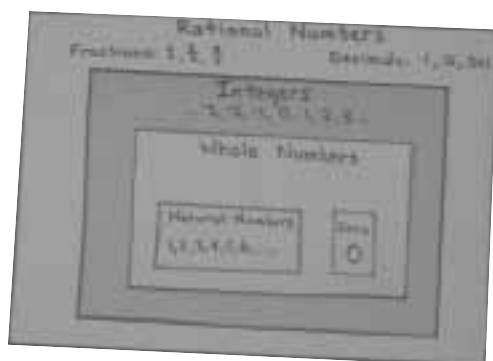

Four-Tab Book

## Rational Numbers: Fractions

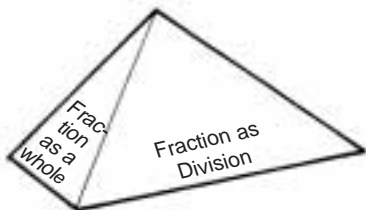

Pyramid Fold

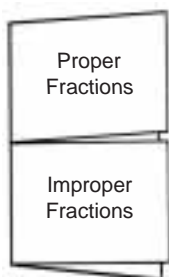

Two-Tab Book

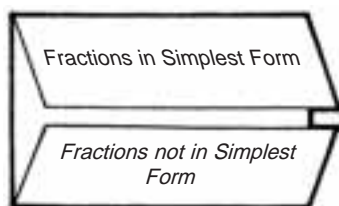

Shutter Fold

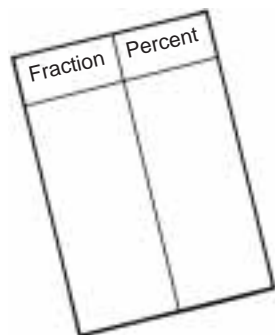

Folded Chart

Skill	Activity Suggestion	Foldable Parts
define	fractions three ways: as part of a whole as multiplication ( $\frac{3}{5}$ means 3 times $\frac{1}{5}$ ) as division ( $\frac{3}{5}$ means 3 divided by 5)	3
differentiate between	proper and improper fractions	2
rename	whole numbers as improper fractions with a given denominator	2
order	ten fractions from least to greatest	10
graph	five fractions on a number line	5
use	a number line to determine if fractions are equivalent	any number
express	six ratios as fractions in simplest form	6
determine	if five fractions are in their simplest form by checking to see if the GCF of the numerator and the denominator is 1	5
list	examples of fractions in simplest form and fractions that are not in simplest form	any number
explain	why it is easier to compare fractions with the same denominator	1
describe	how the least common denominator of fractions could be used to compare them	1
define	a mixed number as the sum of a whole number and a fraction	1
write	mixed numbers as improper fractions and improper fractions as mixed numbers	2
compare	fractions and decimals	2
chart	equivalent fractions and decimals	2
Venn diagram	given specific examples, compare characteristics of like fractions, unlike fractions, and both	3
explain	how to add like and unlike fractions in words and symbols	4
add	fractions with like and unlike denominators	2
subtract	fractions with like and unlike denominators	2
explain	how to subtract fractions with like and unlike denominators	2
compare and contrast	adding and subtracting unlike fractions	2
multiply	fractions with like and unlike denominators	2
explain	how to multiply fractions with like and unlike denominators in words and symbols	4
divide	fractions with like and unlike denominators	2
prove	that dividing by 2 is the same as multiplying by $\frac{1}{2}$ , its multiplicative inverse	2
write	word problems that contain fractions	any number
express	given fractions as percents	2
tell	how you know if a fraction is greater than 100% or less than 1%	1
compare and contrast	a fraction and an algebraic fraction	2
write	six algebraic fractions in simplest form	6

# Rational Numbers: Decimals

Skill	Activity Suggestion	Foldable Parts
order	ten decimals from least to greatest	10
rename	five decimals as fractions	5
explain	why decimals can be written as fractions with denominators that are powers of ten	1
find	equivalent decimals and fractions	2
differentiate	between terminating decimals, repeating decimals, and decimals that do not terminate nor repeat	3
compare and contrast	terminating and repeating decimals	2
find	examples of decimals that do not terminate or repeat	any number
write	four fractions as terminating or repeating decimals	4
define	terminating decimals	1
describe	repeating decimals	1
Venn diagram	characteristics of terminating decimals, repeating decimals, both	3
estimate	sums of six decimals using rounding and describe each	6
find	six sums of decimals and describe the process	6
estimate	six differences of decimals and write about the process	6
find	six differences of decimals and explain the process	any number
state	additive inverses of five decimals example: 8.45 and $-8.45$	5
illustrate	the rule for placement of the decimal point when multiplying decimals	1
explain	in your own words how to divide by a decimal	1
simplify	four expressions with decimals and explain each step	4
evaluate	five expressions with decimals and explain each step	5

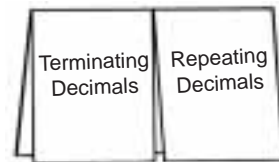

Two-Tab Book

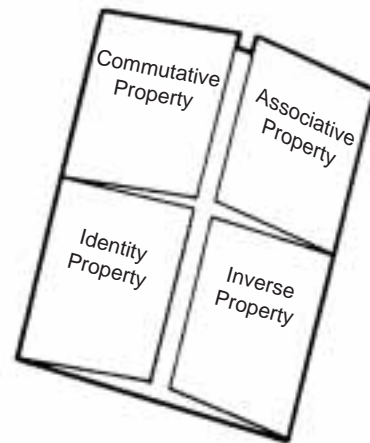

Four-Door Book

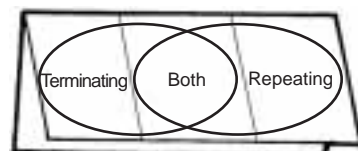

Three-Tab Venn Diagram

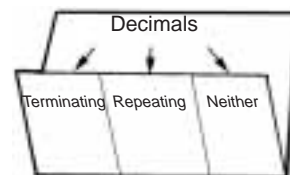
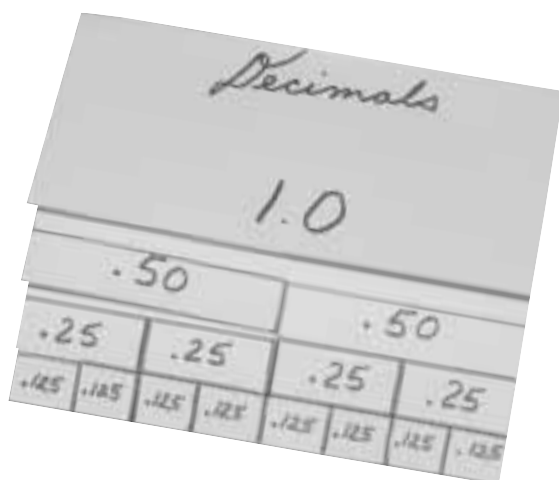

Three-Tab Concept Map

# Percents

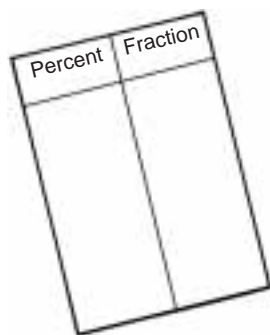

Folded Chart

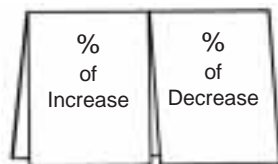

Two-Tab Book

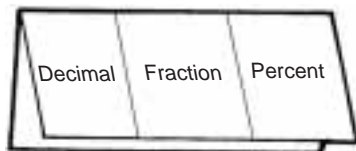

Three-Tab Book



Half Book



Bound Book

Skill	Activity Suggestion	Foldable Parts
define	percent as a ratio that compares a number to 100 or tells how many out of 100	1
explain	why percent also means hundredths, or per hundred	1
write	five percents as fractions and explain	5
use	the percent symbol when writing percents	any number
	equations to solve problems with percents	any number
make a table	that expresses decimals and fractions as percents	3
	that expresses percents as decimals and fractions	3
describe	times when it is more advantageous to use percent and times when it is more advantageous to use fractions	2
use	the percent proportion to write five fractions as percents	5
solve	six problems involving percents	6
find	the percent proportion of four numbers and explain Example: find 10% of 160	4
estimate	three percents and outline the process	3
solve	two percent problems with percent equations and sequence the steps	2
	two real-world problems involving percent	2
write	expressions for percents	any number
use	percents to estimate	any number
explain	how to estimate $x\%$ of a number	1
list	five examples of percents used in everyday life such as weather bureau's rain prediction, interest rates, discounts, and commissions and explain their use	5
describe	percent of change as the ratio of the amount of change to the original amount	1
differentiate	between percent of increase and percent of decrease	2
calculate	percent of increase and percent of decrease	2

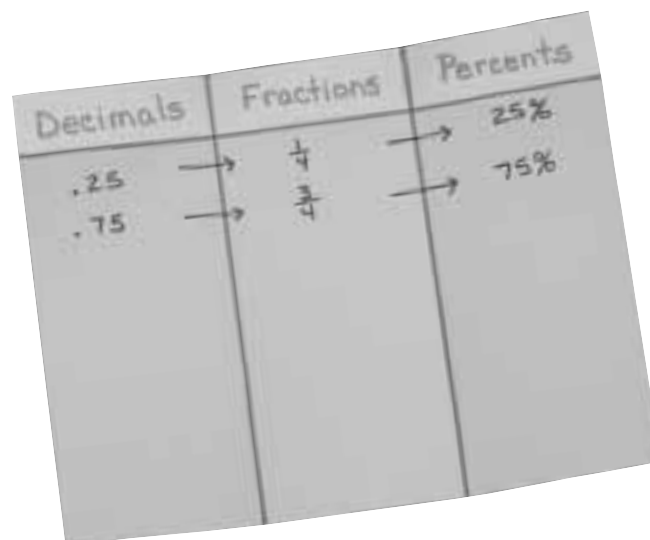

# Ratios

Skill	Activity Suggestion	Foldable Parts
define	ratio as a comparison of two numbers by division	1
write	four ratios four different ways Example: 2 to 3, 2:3, $\frac{2}{3}$ , and $2 \div 3$	4
	five ratios as fractions in simplest form	5
	expressions for five ratios	5
describe	rate as a ratio that is a comparison of two measurements with different units of measurement	1
Venn diagram	characteristics of ratios, rates, and both	3
make a table	that shows five or more ratios and rates as fractions in simplest form	5+
give	three examples of unit rate	3
express	given ratios as unit rates	any number
research	the history of the golden ratio and explain its purpose	2
investigate and discover	three examples of how the golden ratio has been used over the last 4000 years to create art and architecture Example: Pyramid of Khufu in Giza	3
describe	the golden ratio in your own words	1
define	a scale drawing as a drawing that is either smaller or larger than the actual object and give examples of scale drawings	2
explain	scale as the ratio of the lengths on a drawing to the actual lengths of an object	1

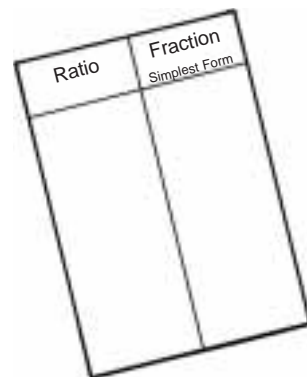

Folded Chart

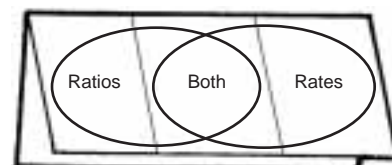

Three-tab Venn diagram

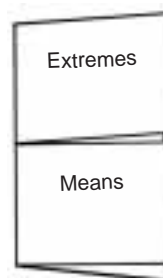

Two-Tab Book

# Proportions

Skill	Activity Suggestion	Foldable Parts
define	proportion as two equal fractions, or an equivalent relationship between two ratios	1
solve	given proportions	any number
determine	if two ratios form a proportion by checking their cross products Example: ratios, check, results	3
state	the property of proportions in your own words	1
define	extremes and means	2
demonstrate	how cross products can be used to tell whether two fractions form a proportion	any number
use	proportions to solve real-world problems	any number
	proportions to estimate populations	any number
Venn diagram	ratios, proportions, both	3
explain	pi as a constant of proportionality and give examples	2

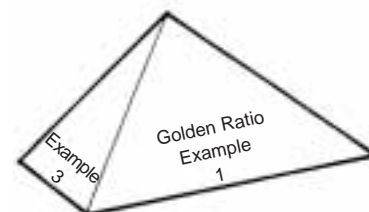

Pyramid Fold

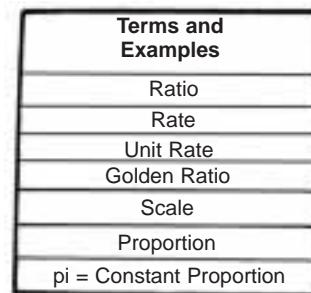

Layered Book  
(4 sheets of paper)

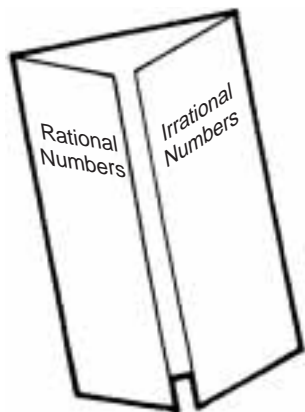

Shutter Fold

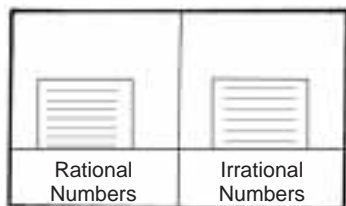

Pocket Book

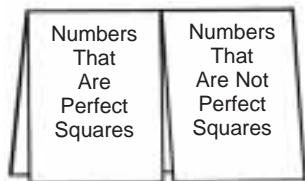

Two-Tab Book

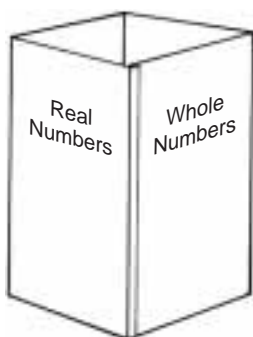

Standing Cube

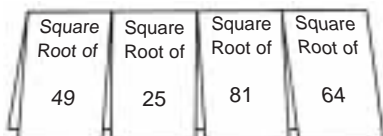

Four-Tab Book

## Irrational Numbers

Skill	Activity Suggestion	Foldable Parts
define	irrational numbers as numbers that cannot be expressed as fractions $\frac{a}{b}$ , where $a$ and $b$ are integers and $b$ does not equal 0	1
explain	irrational numbers in words and symbols	2
determine	whether three given numbers are rational or irrational and explain your reasoning	3
compare and contrast	rational and irrational numbers	2
give examples	of irrational numbers that are less than $-15$	any number
describe	why pi and the square root of 3 are examples of irrational numbers	2

## Real Number System

Skill	Activity Suggestion	Foldable Parts
design a concept map	that shows the set of real numbers is composed of the set of rational numbers and the set of irrational numbers	2
identify	numbers in the real number system	any number
explain	in words and symbols the real number system	2
Venn diagram	the real number system	3
chart	numbers into the categories of whole number, integer, rational, irrational, and real squares and square roots	6
define	a square root as one of two equal factors of a number	1
describe	a square root in words and symbols	2
find	the square root of 49, 25, 81, and 64	4
estimate	square roots	any number
solve	equations by finding square roots	any number
compare and contrast	numbers that are and are not perfect squares	2

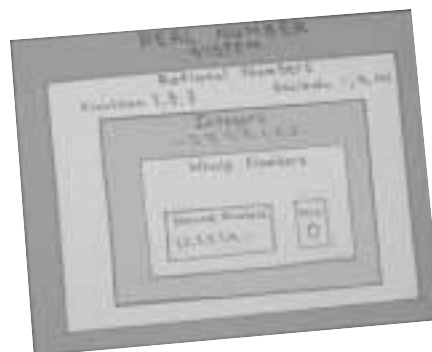

## Sets and Variables

Skill	Activity Suggestion	Foldable Parts
define	a variable as a placeholder used in algebra	1
speculate	as to why variables are usually letters	1
explain	how the use of a variable can help solve algebra problems	1
define	like terms as terms with the same variable	1
compare and contrast	a numeric expression and an algebraic expression, or expressions with and without variables	2
chart	expressions in words and symbols, numerically, and algebraically	3 or 4
state	the Substitution Property of Equality (For all numbers $a$ and $b$ , if $a = b$ , then $a$ may be replaced with $b$ .)	1
demonstrate	the use of the Substitution Property of Equality	1
show	multiplication and division notations used with variables	2
write	the meaning of several algebraic expressions	any number
evaluate	expressions containing variables	any number
translate	verbal phrases into algebraic expressions using variables	2
write	verbal phrases for given algebraic expressions	2
chart	words that can be used to denote addition, subtraction, multiplication, and division when reading or writing algebraic expressions	4
describe	the use of the following symbols in algebra: parentheses, brackets, and braces	3
compare	an independent variable and a dependent variable	2
research	the “who, what, when, where” of: Georg Cantor (1845–1918) developer of the theory of sets	4

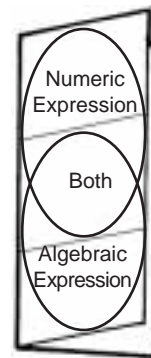

Three-Tab Venn Diagram



Three-Tab Book

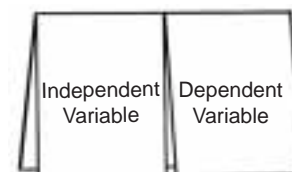

Two-Tab Book

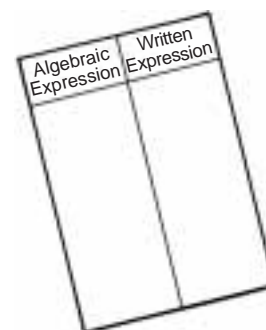
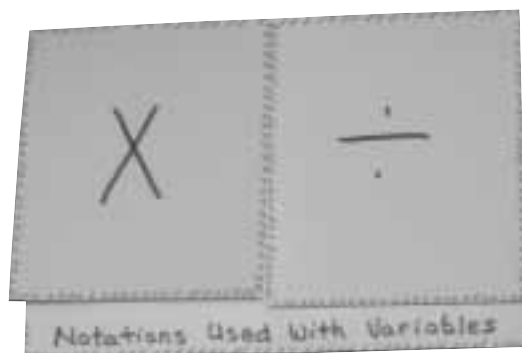

Folded Chart

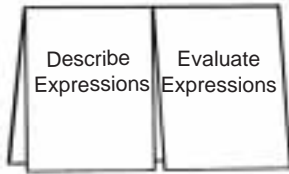

**Two-Tab Book**

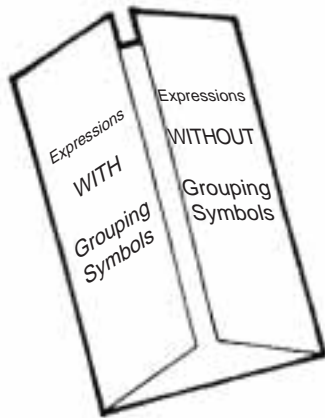

**Shutter Fold**

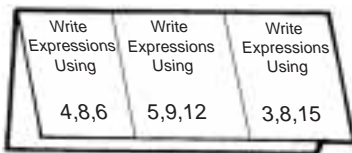

**Three-Tab Book**

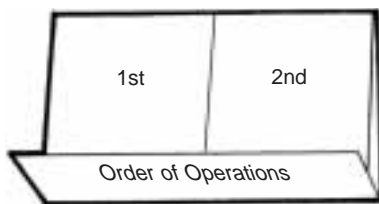

**Two-Tab Matchbook**

## Expressions

Skill	Activity Suggestion	Foldable Parts
define	a mathematical expression as any combination of numbers and operations such as addition, subtraction, multiplication, and division	1
describe	what it means to evaluate an expression	1
demonstrate	how an expression can have several numerical values	any number
explain	why it is important to have an order of operations when evaluating expressions	1
sequence	the steps used to find the value of an expression	any number
evaluate	expressions without grouping symbols using the order of operations	2
	expressions with grouping symbols using the order of operations	2
demonstrate	how the order of operations can be changed using grouping symbols	any number
illustrate	the use of brackets [ ] and parentheses ( )	2
write	ten expressions and find their values	10
show	different ways to indicate multiplication in an expression	2
	different ways to indicate division in an expression	any number
select	three numbers and use them to write as many expressions as you can	3
compare and contrast	expressions with and without variables	2
explain	that an expression is in its simplest form when it has no like terms and no parentheses	1
chart	expressions that are and are not in their simplest form	2
describe	radical expressions and give examples	2
explain	how to add, subtract, multiply and divide radical expressions	4

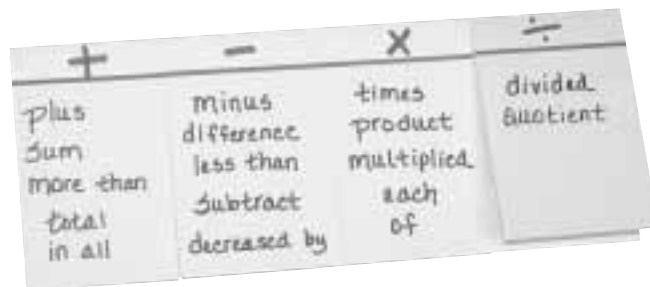



## Properties

Skill	Activity Suggestion	Foldable Parts
write	the Commutative and Associative Properties of Addition and Multiplication numerically and algebraically	4
use	the Commutative Properties of Addition and Multiplication to evaluate expressions	2
rewrite	expressions using the Commutative Property	2
use	the Associative Properties of Addition and Multiplication to evaluate expressions	2
rewrite	expressions using the Associative Property	any number
compare and contrast	the Associative and Commutative Properties	2
describe	the importance of the Identity Properties of Addition and Subtraction	2
describe and use	the Zero Product Property	2
make a table	to show seven properties of addition and multiplication	7
write	the Distributive Property in words and numerically	2
read	the expression $a(b + c)$ as “ $a$ times the quantity $b$ plus $c$ ”	1
describe	in your own words the purpose of the Distributive Property	1
rewrite	expressions different ways using the Distributive Property	any number
restate	expressions using the Distributive Property	any number
show	how the Distributive Property can be used to simplify expressions with like terms	1
make a table	to describe and give examples of: Commutative Property of Addition Commutative Property of Multiplication Associative Property of Addition Associative Property of Multiplication Identity Property of Addition Identity Property of Multiplication Zero Product Property	any number
use	the Product Property of Radicals and the Quotient Property of Radicals to evaluate expressions	2

Seven properties of addition and multiplication
1
2
3
4
5
6
7

Layered Book  
(4 sheets of paper)

Expression	Simplest form	Not simplest form

Folded Chart

Expression	Rewritten expression

Layered Book  
(3 sheets of paper)



Product Property	Quotient Property
------------------	-------------------

Two-Tab Book

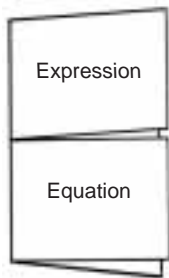

Two-Tab Book

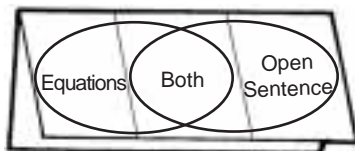

Three-Tab Venn Diagram

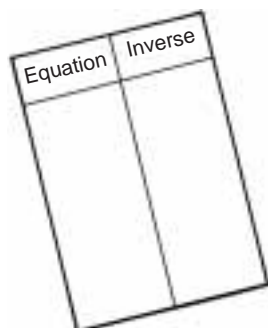

Folded Chart

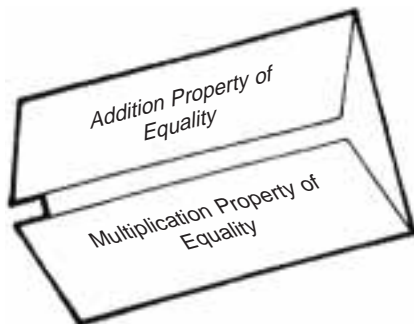

Shutter Fold

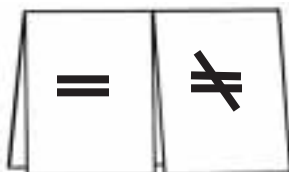

Two-Tab Book

# Equations

Skill	Activity Suggestion	Foldable Parts
differentiate between	an expression and an equation	2
compare	an equation to a balance	2
Venn diagram	characteristics of equations, open sentences, and both	3
list	examples of equations	any number
tell	about equations that have no solution, or have a solution set that is null or empty	2
draw	two symbols that represent the empty or null set	2
compare and contrast	solution sets that are never true and solution sets that are always true	2
explain	why equations that contain variables are called open sentences	1
find	values for variables that make equations true	any number
explain	the solution of an equation	1
solve	equations with variables and write about how you found the solution	2
chart	solutions and open sentences	2
	equations with variables on each side	any number
solve	equations using inverse operations	any number
	how inverse operations “undo” each other	1
write	inverse operations for addition equations	2
	inverse operations for subtraction equations	2
solve	equations using the Addition Property of Equality	any number
solve	equations using the Subtraction Property of Equality	any number
write	examples of equations that are and are not equivalent	2
explain	when to use the Addition Property of Equality to solve an equation and give examples	2
solve	equations using the Division Property of Equality	any number
	equations using the Multiplication Property of Equality	any number
	six equations using rational numbers	6
	six equations with variables on each side	6
	six equations with grouping symbols	6
	ten equations that have an infinite number of solutions	10
explain	what is meant by the root, or roots, of three equations	3
use	integers in equations	any number
solve	equations containing rational numbers	any number
	equations with two or more operations	any number
write	five verbal problems for equations with two or more operations	5

# Inequalities

Skill	Activity Suggestion	Foldable Parts
define	inequalities as mathematical sentences that contain greater than or less than symbols	1
write	inequalities that are true and inequalities that are false	2
	inequalities that are open, or contain a variable that must be replaced with a number	any number
chart	inequalities that are true, false, and open	3
explain	inequality signs that are a combination of the equals sign and the inequality symbols	2
chart	common phrases that are heard in everyday life that correspond to inequalities	any number
Venn diagram	methods for solving equations, inequalities, and both	3
solve	ten inequalities	10
write	sentences for inequalities and translate sentences into inequalities	2
	five inequalities and graph the solutions	5
solve	inequalities mentally	any number
state	in your own words the Addition Property of Inequality and give two examples	2
explain	the Subtraction Property of Inequality to someone	1
solve	inequalities by using the Addition and Subtraction Properties of Inequality	2
describe	the Addition and Subtraction Properties of Inequality in words and symbols	4
write	the Multiplication and Division Properties of Inequalities in words and symbols	4
solve	inequalities by multiplying or dividing by a positive number	2
	inequalities by multiplying by a negative number	2
solve	inequalities that involve more than one operation	2
Venn diagram	method for solving an inequality involving multiplication, and for solving an inequality involving division, both	3
use	inequality symbols when comparing fractions	any number
solve	inequalities containing rational numbers	any number
Venn diagram	solving an inequality with rational numbers, solving an inequality involving integers	3
solve	inequalities with multiple steps	any number
write	verbal problems with inequalities	any number
describe	a compound inequality as two inequalities connected by “or” or “and” and give examples	2

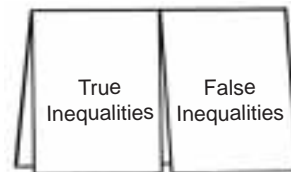

Two-Tab Book

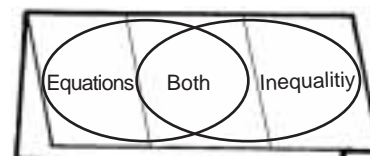

Three-Tab Venn Diagram

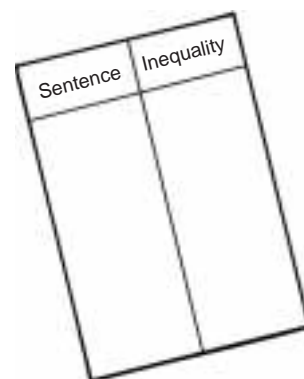

Folded Chart

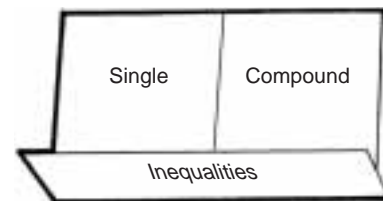

Two-Tab Matchbook

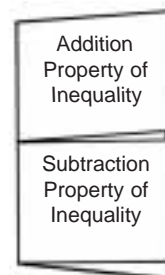

Two-Tab Book

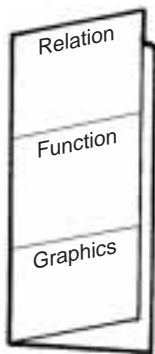

Three-Tab Book

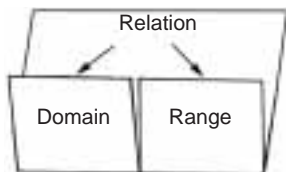

Two-Tab Concept Map Book

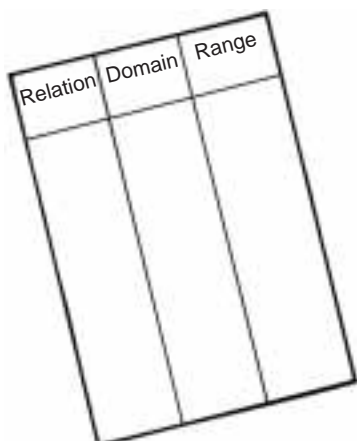

Folded Chart

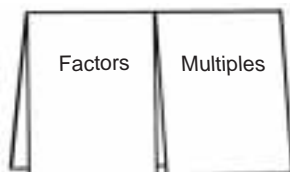

Two-Tab Book



Bound Book

## Relations and Functions

Skill	Activity Suggestion	Foldable Parts
define	relations, functions, and graphing	3
Venn diagram	all functions are relations, but not all relations are functions	3
make	a concept map to show a relation as domain and range	2
write	the domain and range of given relations	3
define	function as a relation in which each element of the domain is paired with exactly one element in the range	1
graph	five relations to determine if they are functions	5
determine	whether four relations are functions by using the vertical line test	4
use	functions to describe relationships between two quantities	2
make	function tables	any number
use	function tables to find output values	any number
describe	the inverse of a relation	1



# Factors

Skill	Activity Suggestion	Foldable Parts
explain	that the factors of a whole number divide that number with a remainder of 0	1
use	the phrase “divisible by” when describing the factors of a given number	1
determine	whether one number is a factor of another	any number
make a chart	of divisibility rules, examples, and descriptions	3
differentiate between	even and odd numbers and explain how they relate to factors	2
describe	multiplication facts as they relate to factors	1
explain	why 1 is a factor of every nonzero number	1
mentally determine	what five numbers are divisible by Example: 27, 64, 189, 370, 455	5
chart	numbers with exactly 2, 3, 4, 5, and 6 factors	5
define	the greatest common factor of two or more numbers as the greatest factor these numbers have in common	1
list	the factors of three sets of numbers and find the greatest factor each set has in common	3
read	GCF as the “greatest common factor”	1
use	prime factorization to find the GCF of a set of numbers	any number
explain	how the product of the common prime factors of two or more monomials is their GCF	1
Venn diagram	find the GCF of two numbers by making a Venn diagram of their factors	3
define	relatively prime numbers as numbers with 1 as their only common factor	1
determine	whether given pairs of numbers are relatively prime	any number
define	a prime number as a whole number greater than one that has exactly two factors, one and itself	1
	a composite number as a whole number greater than one that has more than two factors	1
differentiate between	prime and composite numbers	2
prove	that a composite number can always be expressed as a product of two or more products	any number
explain why	0 and 1 are considered neither prime nor composite	2
list	the factors of 1 and explain your list	1
describe	every whole number greater than 1 is either prime or composite	1

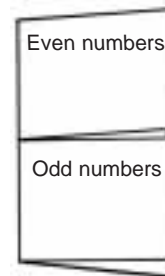

Two-Tab Book

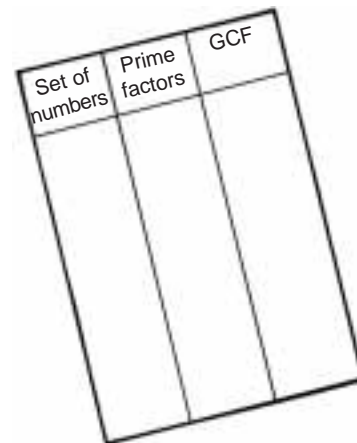

Folded Chart

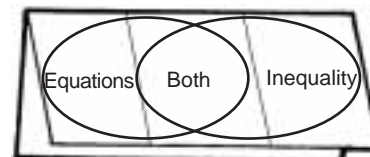

Three-Tab Venn Diagram

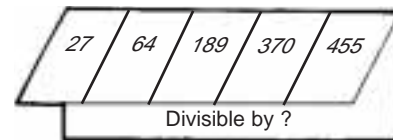

Five-Tab Book

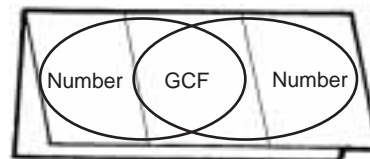

Three-Tab Venn Diagram

Multiples of
2
3
4
5
6
7
8
9
10

**Layered Book**  
(5 sheets of paper)

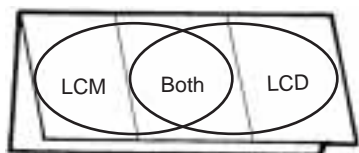

**Three-Tab Venn Diagram**

First Number	Second Number	LCM

**Folded Chart**

# Multiples

Skill	Activity Suggestion	Foldable Parts
define	a multiple of a number as a product of that number and a whole number	1
chart	the multiples of 2, 3, 4, 5, 6, 7, 8, 9, and 10	9
differentiate	between factors and multiples	2
find	the common multiples of two numbers such as 2 and 5	2
determine	the least common multiple of two numbers	2
read	LCM as Least Common Multiple	1
use	a Venn diagram to find the LCM of two numbers using their prime factorization	3
find	the LCM of a set of numbers or algebraic expressions	any number
read	LCD as Least Common Denominator	1
find	the LCD for given pairs of fractions	any number
Venn diagram	finding a LCM, finding a LCD, both	3
explain	why fractions need the same denominator to be compared	1
find	factors and multiples	2

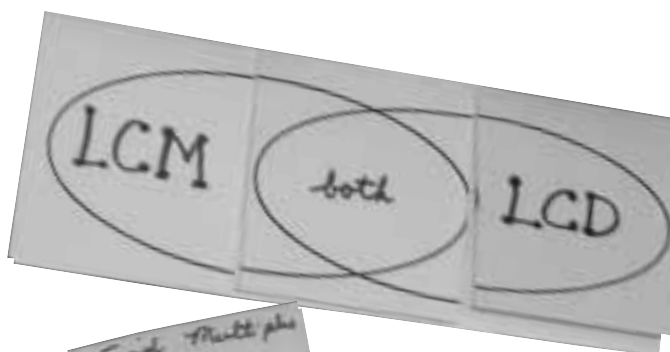

Find Multiples of 9...

2
3
4
5
6
7
8
9
10

# Monomials and Polynomials

Skill	Activity Suggestion	Foldable Parts
define	a monomial as an integer, a variable, or a product of integers and one or more variables	1
	a constant as a monomial that is a real number	1
Venn diagram	characteristics of monomials, constants, and both	3
list	ten examples of monomials and explain what they have in common	10
determine	whether an expression is or is not a monomial and explain your reasoning	2
multiply	monomials	any number
describe	in words and symbols the Power of a Monomial	2
Venn diagram	Power of a Product Property, Power of a Power Property, both = Power of a Monomial	3
divide	monomials	any number
explain	the degree of a monomial as the sum of the exponents of its variables	1
list	four monomials and their degrees	4
chart	examples of polynomials, or algebraic expressions, with one, two, three, and many terms	4
	examples of monomials, binomials, and trinomials	3
define	polynomial as a monomial, or a sum of monomials, and give four examples	4
find	the degree of three polynomials using the following: 1. find the degree of each term 2. determine the greatest degree of the terms 3. state the greatest degree of any term as the degree of the polynomial	3
add	polynomials and write about the process	any number
subtract	polynomials and write about the process	any number
find	the additive inverses of five polynomials	5
multiply	a polynomial by a monomial and outline the steps	2
simplify	four expressions involving polynomials	4
use	the FOIL method to multiply two binomials and the four steps	4

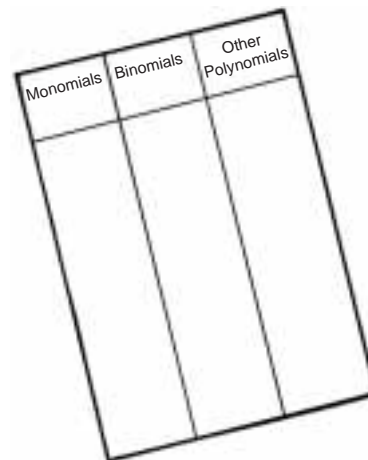

Folded Chart

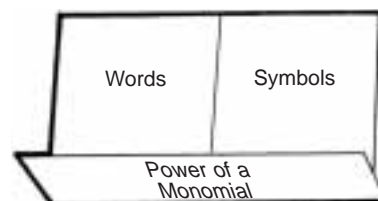

Two-Tab Matchbook

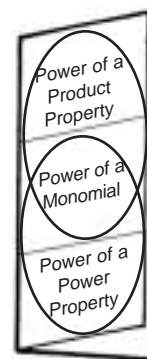

Three-Tab Venn Diagram

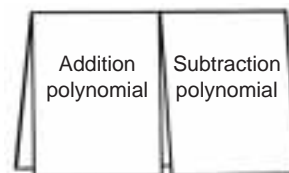

Two-Tab Book

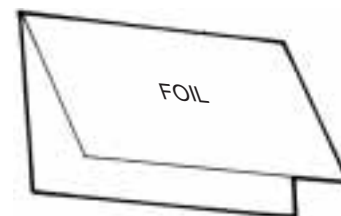

Half Book

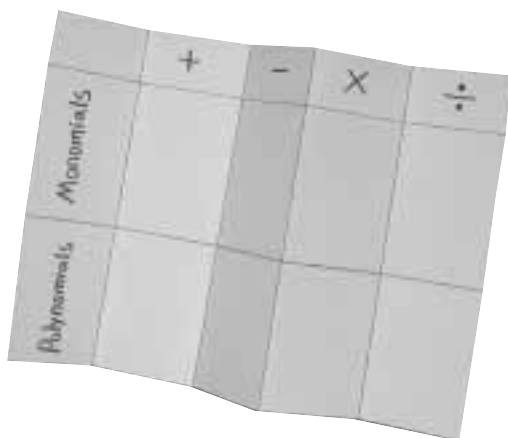

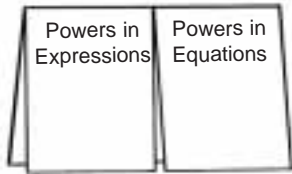

Two-Tab Book

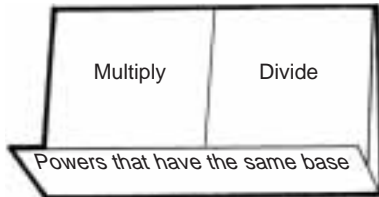

Two-Tab Matchbook

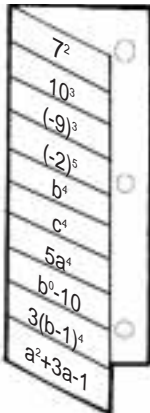

Vocabulary Book

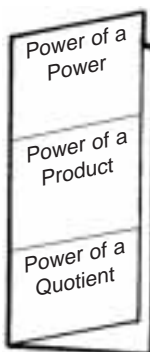

Three-Tab Book

# Powers and Exponents

Skill	Activity Suggestion	Foldable Parts
define	powers as numbers that are expressed using exponents	1
read	expressions containing powers	any number
describe	how the second and third powers have special names related to geometry	2
write	expressions containing powers	any number
	expressions containing powers as multiplication expressions	any number
write	powers as multiplication expressions	any number
explain	how to multiply powers that have the same base	1
	how to divide powers that have the same base	1
compare and contrast	products of powers and quotients of powers	2
use	powers in expressions and equations	2
define	scientific notation as numbers written as the product of a factor and a power of 10	1
write	ten numbers using scientific notation	10
read	scientific notation	any number
order	numbers written in scientific notation	any number
compare	numbers in scientific notation with positive and negative exponents	2
use	scientific notation to evaluate five equations	5
outline	Properties of Powers—Power of a Power, Power of a Product, and Power of a Quotient	3
explain	how exponents are used to tell how many times a number is used as a factor	1
	rational exponents in words and symbols	2
define	the term base as it relates to exponents	1
write	four expressions using exponents	4
	three expressions with rational exponents in simplest radical form	3
evaluate	five expressions using exponents	5
show	expressions in either exponential or radical form	2
	numbers in standard and expanded form	2
use	the order of operations to evaluate algebraic expressions with powers	any number
write	expressions using positive and negative exponents	2
compare	the square of a difference and the square of a sum	2
tell	whether given expressions are in simplest form and why	2





# Sequences

Skill	Activity Suggestion	Foldable Parts
define	an arithmetic sequence	1
explain	how to describe even and odd numbers as arithmetic sequences	2
differentiate between	numbers in a sequence and numbers in an arithmetic sequence	2
compare and contrast	sequences that are and are not arithmetic	2
describe	the terms of a sequence	1
find	the next terms of five given sequences	5
determine	the common differences of three arithmetic sequences	3
write	an original arithmetic sequence	1
outline	the steps you took to write an arithmetic sequence	
write	expressions that represent terms in a sequence	any number
research	the Fibonacci sequence and why the Fibonacci sequence is not arithmetic	2
define	a geometric sequence	1
explain	how each term in a geometric sequence increases or decreases by a common factor, called the common ratio	2
determine	if given sequences are geometric	2
find	the common ratio of a geometric sequence and list the next five terms	3

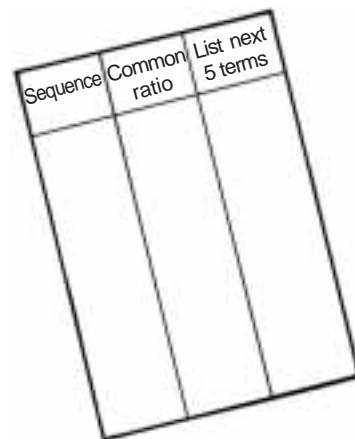

Folded Chart

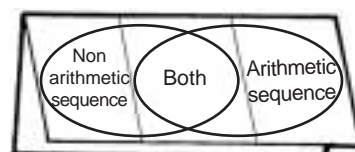

Three-Tab Venn Diagram

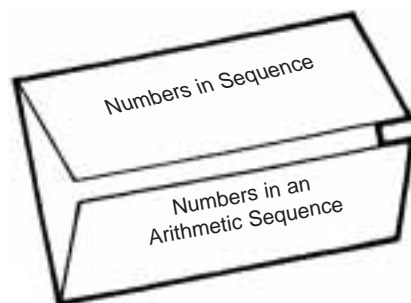

Shutter Fold

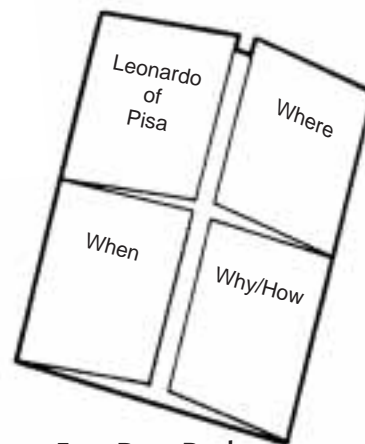
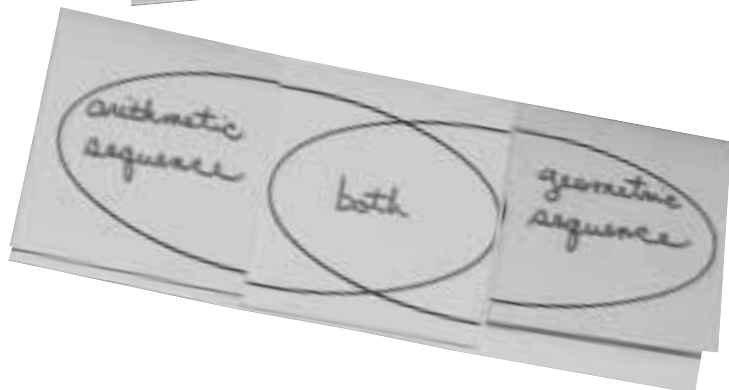

Four-Door Book

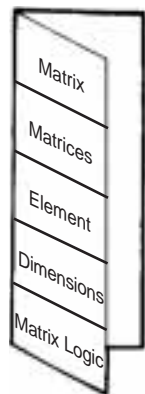

Five-Tab Book

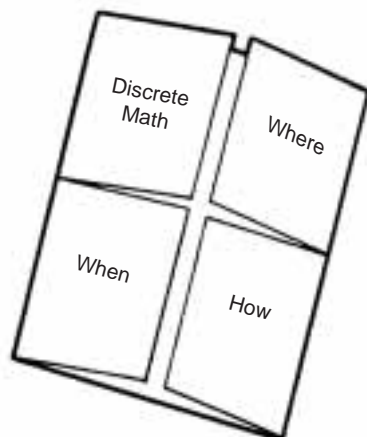

Four-Door Book

## Matrices

Skill	Activity Suggestion	Foldable Parts
define	matrix, matrices, element, dimensions, matrix logic	5
explain	how matrices organize data and give an example	2
give	two examples of square matrices	2
use	the singular word “matrix” and its plural form “matrices” correctly	2
compare and contrast	a matrix and a table	2
illustrate	how a matrix can be used to add, subtract, and multiply quantities	3
describe	how a matrix can be used to solve systems of equations with one, two, and three variables	3
research	the “what, where, when, why/how” of discrete mathematics	4
	Nine Chapters on the Mathematical Art, 250 B.C.	4
list	and explain algebraic rules for using matrices: scalar multiplication of a matrix, addition and subtraction of matrices, and multiplying matrices	any number
give	two examples of probability matrices	2
write	the identity matrices for three square matrices	3
find	the inverses of three $2 \times 2$ matrices	3
compare and contrast	the multiplicative inverse for real numbers to the inverse matrix	2

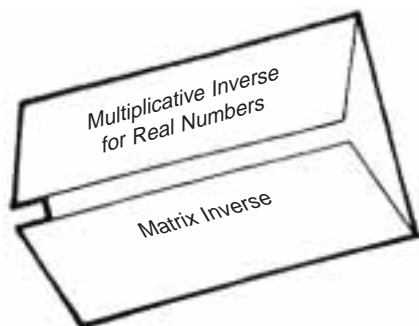

Shutter Fold

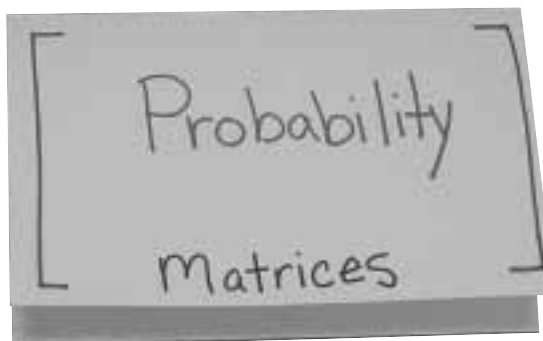

## Points

Skill	Activity Suggestion	Foldable Parts
describe	a point as a specific location in space with no size or shape that is represented by a dot and named with a capital letter	1
identify	and model points and coplanar points	2
graph	eight ordered pairs on a coordinate plane	8
find	the distance between two points on a number line and two points in a coordinate plane	2
identify	how many end points a line, line segment, and a ray have	3

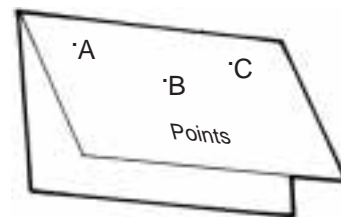

Half Book

## Lines and Line Segments

Skill	Activity Suggestion	Foldable Parts
define	a line as a collection of points that extends in two directions, shown by arrowheads	1
list	two ways a line can be named	2
explain	a line segment as part of a line containing two endpoints and all of the points between	1
describe	how line segments are named	1
draw	and name five line segments	5
identify	and model lines that do and do not intersect	2
differentiate	between parallel lines and perpendicular lines	2
	between lines that intersect at a right angle and those that do not	2
illustrate	and explain a line called a <i>transversal</i>	2
find	the slopes of lines and use slope to identify parallel and perpendicular lines	2

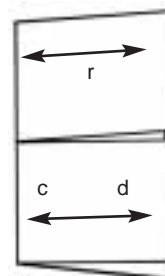

Two-Tab Book

## Rays

Skill	Activity Suggestion	Foldable Parts
define	a ray as a portion of a line that extends from one point infinitely in one direction	1
describe	how a ray is named	1
Venn diagram	characteristics of a line segment, a ray, and both	3
illustrate	how two rays form and define an angle	2
compare and contrast	collinear and noncollinear rays	2

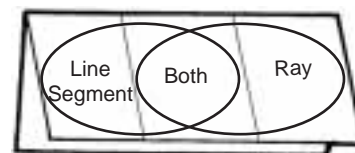

Three-Tab Venn Diagram

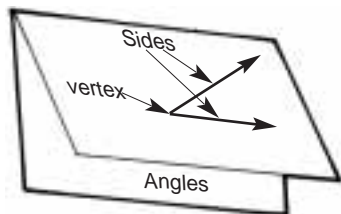

**Folded Book**

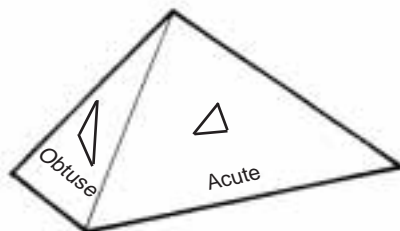

**Pyramid Fold**

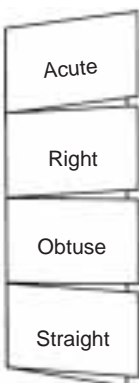

**Four-Tab Book**

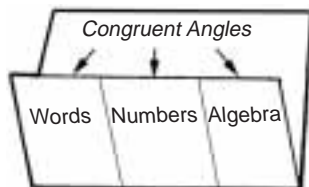

**Three-Tab Concept Map**

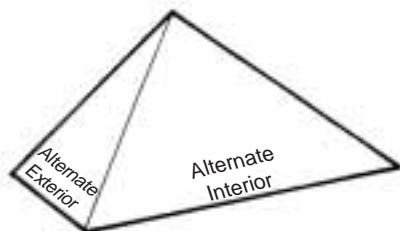

**Pyramid Fold**

## Angles

Skill	Activity Suggestion	Foldable Parts
describe	an angle as two rays with the same endpoint	1
draw and label	the parts of an angle—vertex and sides	2
make	a concept map for “angles”	any number
summarize	and demonstrate how angles are measured and named	2
measure and name	ten angles using a protractor and report the measures in degrees	10
demonstrate	how a protractor can be used to draw an angle of a given measure	any number
differentiate	between acute, obtuse, and right angles	3
Venn diagram	characteristics of acute angles, obtuse angles, and both	3
classify	angles as acute, right, obtuse, or straight	4
explain	how an angle separates a plane into three parts: interior of the angle, exterior of the angle, and the angle itself	3
draw	an angle that is congruent to a given angle	1
construct	the bisectors of four given angles	4

## Angle Relationships

Skill	Activity Suggestion	Foldable Parts
justify	a straight line being called a “straight angle”	1
use	the term “transversal” when describing a line that intersects two parallel lines	1
draw	two intersecting lines and measure the angles formed	2
	parallel lines and measure the angles formed	2
	perpendicular lines and a transversal and explain why intersecting perpendicular lines form four right angles	2
show	rays and line segments can be perpendicular	2
describe	how the following are formed and give examples: vertical angles, adjacent angles, linear pair	3
differentiate	between complementary and supplementary angles	2
explain	alternate interior angles, alternate exterior angles, and corresponding angles	3
prove	that corresponding angles are congruent, alternate interior angles are congruent, and alternate exterior angles are congruent	3
compare and contrast	supplementary and complementary angles	2

# Planes

Skill	Activity Suggestion	Foldable Parts
describe	a plane as a flat surface with no edges, or boundaries	1
explain	why lines in the same plane either intersect or are parallel	2
define	skew lines as two lines that do not intersect and are not in the same plane	1
draw	two examples of skew lines and explain why they are skew lines	2
find similarities and differences	between intersecting, parallel, and skew lines	2
Venn diagram	characteristics of parallel lines, skew lines, and both	3
illustrate	a rectangular prism and explain how it is formed by six planes	2
find	five examples of planes in your daily life	5
model	planes that do and do not intersect	2
write	five plane relationships and draw and label a figure for each	5
describe	and give four examples of coplanar points	5
compare	plane geometry and spherical geometry	2

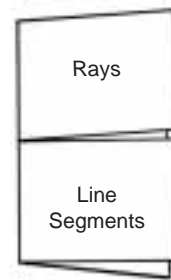

Two-Tab Book

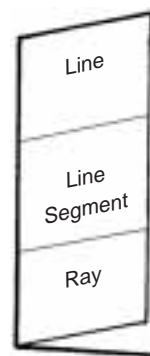

Three-Tab Book

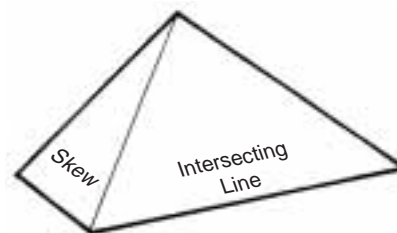
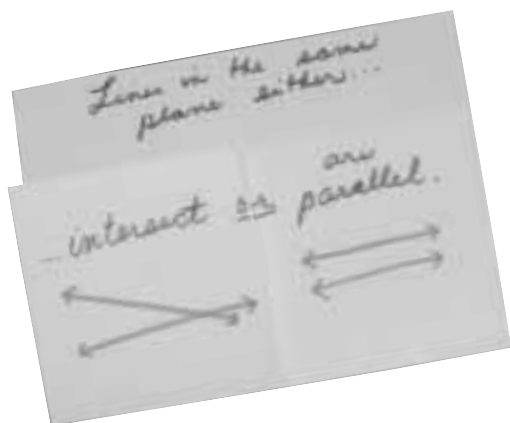

Pyramid Fold

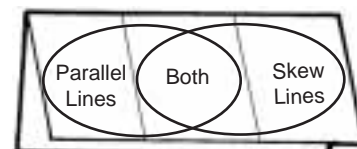

Three-Tab Venn Diagram

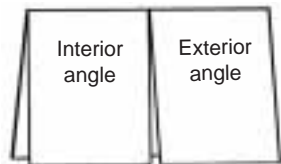

Two-Tab Book



Vocabulary Book

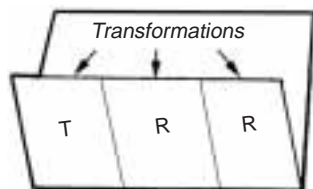

Three-Tab Concept Map

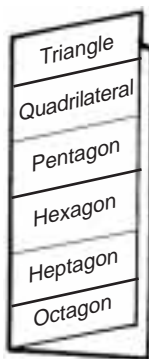

Six-Tab Book

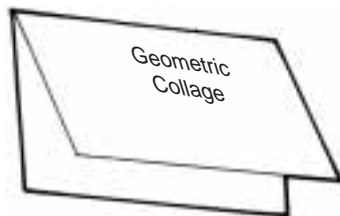

Half Book

# Polygons

Skill	Activity Suggestion	Foldable Parts
define	polygons as simple closed figures in a plane formed by three or more line segments	1
classify	polygon as convex or concave	2
determine	the sum of the measures of the interior and exterior angles of a polygon	2
	how and why polygons are classified by their sides	2
explain	the meaning of the following prefixes—tri-, quad-, penta-,hexa-, hepta-, octa-, nona-, deca-, dodeca-, n-	9
draw and label	a triangle, a quadrilateral, a pentagon, a hexagon, an octagon, and a decagon	6
label	the vertices of the polygons you draw	any number
define	a diagonal as a line segment that joins two nonconsecutive vertices	1
explain	diagonals can not be drawn in a triangle, but can be drawn in any polygons with more than three sides	2
make a table	to show the number of sides, diagonals, and triangles formed in several different polygons—quadrilateral, pentagon, hexagon, heptagon, octagon	5
make a concept map	that shows a regular polygon is equilateral and equiangular	2
show	examples of interior and exterior angles of a polygon	2
differentiate between	polygons that are regular and polygons that are not regular	2
find	the sum of the measures of the interior angles of four different polygons heptagon = $900^\circ$ nonagon = $1260^\circ$ decagon = $1440^\circ$ dodecagon = $1800^\circ$	4
make a table	to show the measures of the interior and exterior angles of three regular polygons	3
find	the perimeters of different polygons	any number
make a collage	of pictures of polygons	1
draw	a tessellation	1
determine	if three polygons will each tessellate	3
observe	tessellations in the form of quilts, fabric patterns, modern art, and more	any number
identify	regular and semi-regular (uniform) tessellations	2
define	transformations as movements of geometric figures	1
make a concept map	to show three types of transformations: translation, rotation, and reflection	3
draw	examples of translations, rotations, and reflections	3

# Triangles

Skill	Activity Suggestion	Foldable Parts
define	a triangle as a three-sided polygon formed by three line segments that intersect only at their endpoints	1
	similarity of triangles as reflexive, symmetric, and transitive	3
	medians, altitudes, angle bisectors, and perpendicular bisectors	4
draw and label	a triangle and its vertices	2
name	triangles by their vertices	any number
find	the areas of three triangles	3
measure	the angles of four triangles	4
draw a conclusion	about the sum of the measures of the angles of all triangles	1
describe	the six types of triangles—acute, right, obtuse, equilateral, isosceles, and scalene	6
explain	how triangles are classified and classify four triangles by their angles and sides	4
draw and describe	two congruent triangles and their corresponding parts	2
make	a concept map on congruent triangles that explains how their corresponding sides are congruent and their corresponding angles are congruent	2
explain	how to find the area of a triangle in words and symbols	2
make a table	to define and give examples of the following: SSS, SAS, ASA, AAS	4
write	the Triangle Inequality Theorem and use it to show that some sets of line segments cannot be used to form triangles	2

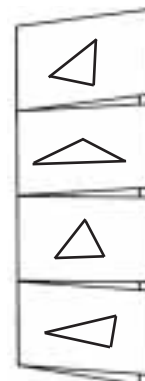

Four-Tab Book

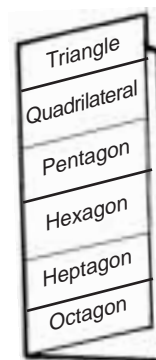

Six-Tab Book

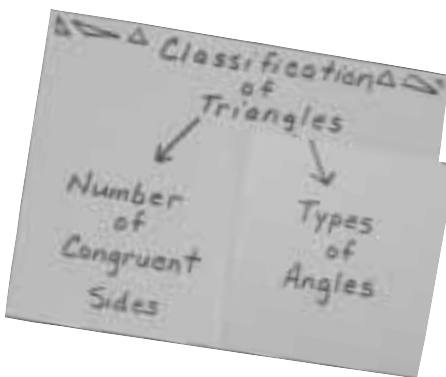
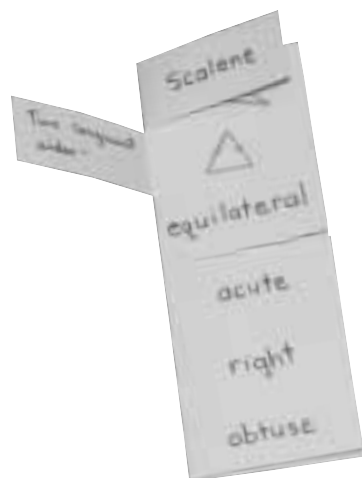

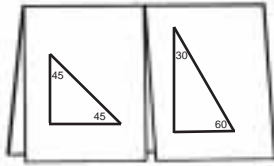

Two-Tab Book

# Right Triangles

Skill	Activity Suggestion	Foldable Parts
label	the parts of a right triangle—right angle, legs, hypotenuse	3
research	the history of the Pythagorean Theorem	4
explain	the Pythagorean Theorem in words and symbols	2
use	the Pythagorean Theorem to find the length of a side of a right triangle	1
determine	whether a triangle is a right triangle and explain your reasoning	2
describe	how to find the length of a leg of a right triangle if you know the lengths of the hypotenuse and the other leg	1
draw and label	a diagram to show the three altitudes of a right triangle	2
construct	right triangles from a square and form an equilateral triangle	2
compare and contrast	45°–45° right triangles, and 30°–60° right triangles	2
	tests for triangle congruence and tests for congruence of right triangles	2
illustrate	LL, HA, and LA as tests for congruence of right triangles	3

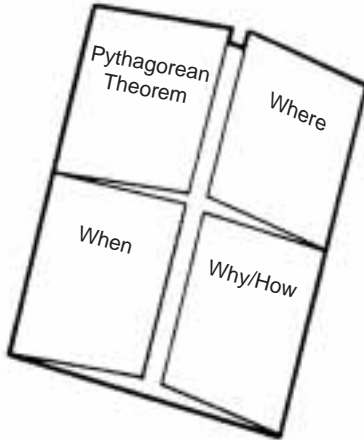

Four-Door Book



Three-Tab Book

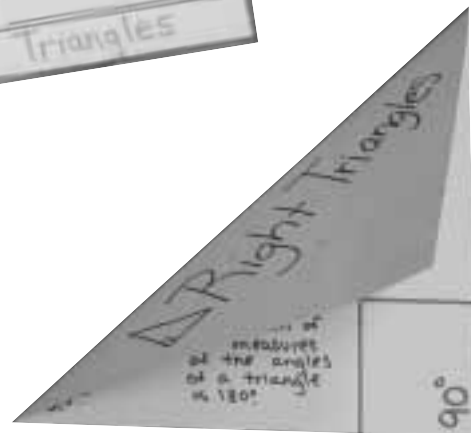
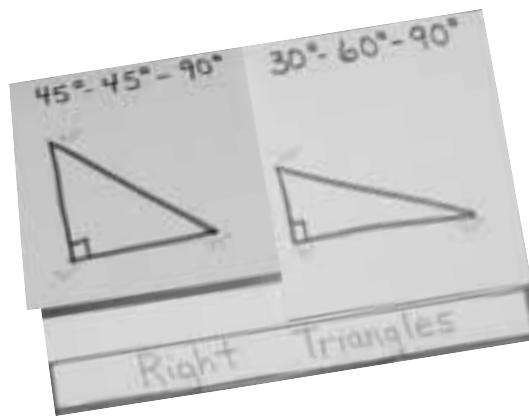



## Right Triangle Trigonometry

Skill	Activity Suggestion	Foldable Parts
describe	trigonometry as the study of triangle properties and relationships	1
explain	the etymology of the word trigonometry	1
define	trigonometric ratios as the ratios of the measures of the sides of a right triangle	1
investigate	the following trigonometric ratios—sine, cosine, tangent ratios	3
report on	the trigonometric ratios sine, cosine, and tangent in words and symbols	3
compare and contrast	the sine ratio with the cosine ratio	2
tell	how to decide whether to use sine, cosine, or tangent when trying to measure an acute angle in a right triangle	3
describe	an angle of elevation and how it is formed by a horizontal line and a line of sight above it	2
show	an angle of depression and how it is formed by a horizontal line and a line of sight below it	2
draw	a diagram of an angle of elevation and an angle of depression	2
Venn diagram	characteristics of angle of elevation, an angle of depression, and both	3

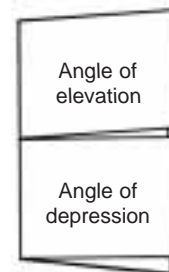

Two-Tab Book

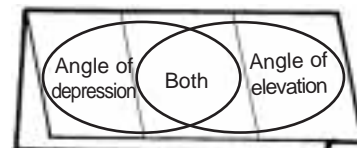

Three-Tab Venn Diagram

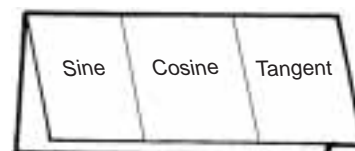

Three-Tab Book

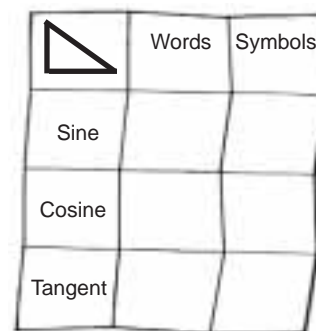

3 x 4 Folded Table

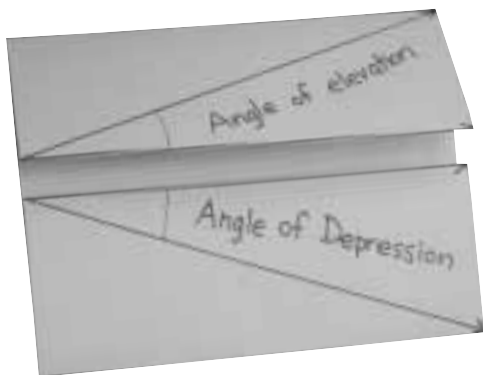

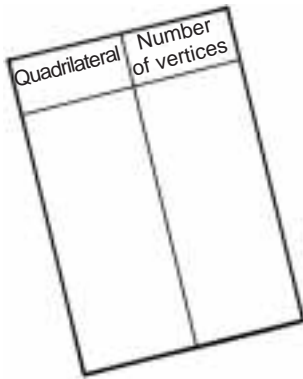

Folded Chart

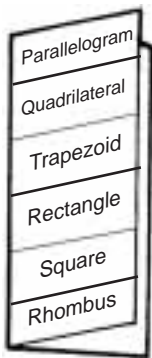

Six-Tab Book

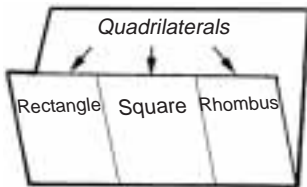

Three-Tab Concept Map

# Quadrilaterals

Skill	Activity Suggestion	Foldable Parts
define	a quadrilateral as a closed figure formed by four line segments that intersect only at their endpoints	1
draw and label	a quadrilateral and its vertices	2
compare and contrast	a quadrilateral and a non-example of a quadrilateral	2
measure	the angles of several quadrilaterals	any number
draw a conclusion	about the sum of the measures of the angles of a quadrilateral	1
explain	how quadrilaterals can be classified	1
describe	six types of quadrilaterals: 1. quadrilaterals with no pairs of parallel lines 2. parallelogram = quadrilateral with two pairs of parallel sides 3. trapezoid = quadrilateral with exactly one pair of parallel sides 4. rectangle = parallelogram with four congruent angles 5. square = parallelogram with congruent sides and congruent angles 6. rhombus = parallelogram with congruent sides	6
make a concept map	that shows the six types of quadrilaterals	6
illustrate	different quadrilaterals and their diagonals	any number

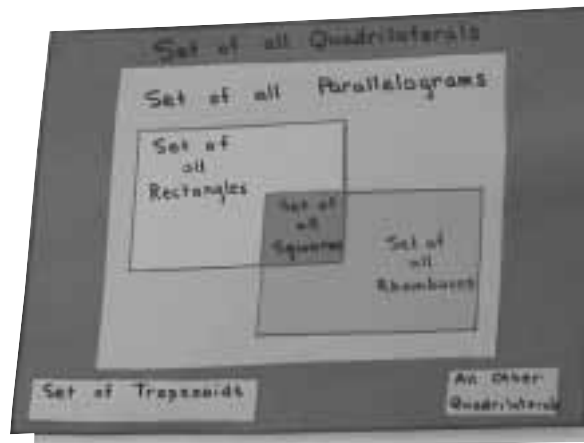

# Squares, Rectangles, and Rhombi

Skill	Activity Suggestion	Foldable Parts
describe	a square and a rectangle in words and symbols	2
Venn diagram	characteristics of a square, a rectangle, and both	3
describe	and illustrate two different quadrilaterals with four right angles—a square and a rectangle	2
find	the perimeters of rectangles, squares, and rhombi	3
	the areas of rectangles, squares, and rhombi	3
describe	equilateral and equiangular figures	2
draw	a square and a rectangle with the same area on grid paper	2
illustrate	the diagonals of squares and rectangles	2
make a table	to compare and contrast the following characteristics of squares and rectangles: <ul style="list-style-type: none"> <li>• are diagonals congruent?</li> <li>• are pairs of opposite sides congruent?</li> <li>• are diagonals perpendicular?</li> <li>• is one pair of opposite sides parallel and congruent?</li> </ul>	any number
summarize	and diagram the properties of a rectangle: <ul style="list-style-type: none"> <li>• opposite sides are congruent and parallel</li> <li>• opposite angles are congruent</li> <li>• consecutive angles are supplementary</li> <li>• diagonals are congruent and bisect each other</li> <li>• all four angles are right angles</li> </ul>	5
compare and contrast	squares and rhombi	2
diagram	the diagonals of a rhombus and prove that they are perpendicular	2
	the diagonals of a rhombus and show how they bisect opposite angles	2
Venn diagram	characteristics of rhombi, rectangles, and both	3

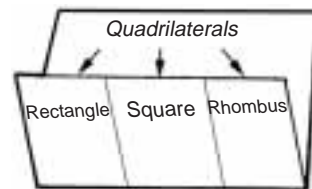

Three-Tab Concept Map

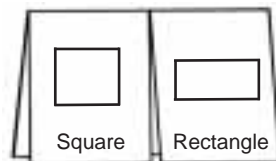

Two-Tab Book

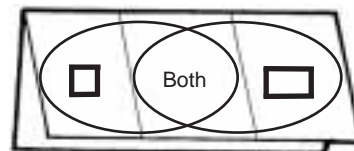

Three-Tab Venn Diagram

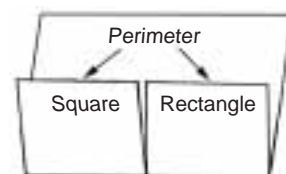

Two-Tab Concept Map

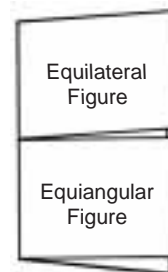

Two-Tab Book

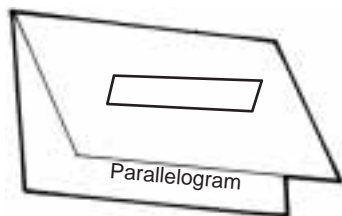

Half Book

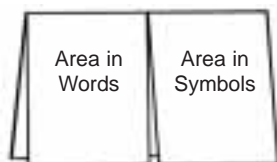

Two-Tab Book

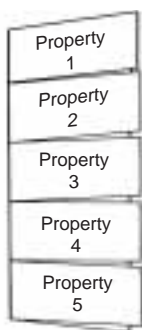

Five-Tab Book

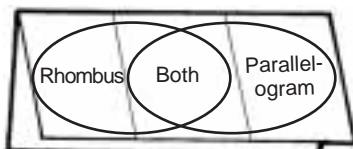

Three-Tab Venn Diagram

## Parallelograms

Skill	Activity Suggestion	Foldable Parts
define	a parallelogram as a four-sided figure with both pairs of opposite sides parallel	1
draw	an example of a parallelogram	1
find similarities	between a general quadrilateral and a parallelogram	2
label	the base and the height of a parallelogram	2
find	the area of given parallelogram by multiplying the measures of the base and the height	any number
illustrate	a parallelogram and show its diagonals	2
describe	how to find the area of a parallelogram in words and in symbols	2
diagram	and explain the following five properties of parallelograms: <ul style="list-style-type: none"> <li>• opposite sides are parallel</li> <li>• opposite sides are congruent</li> <li>• opposite angles are congruent</li> <li>• consecutive angles are supplementary</li> <li>• the diagonals bisect each other</li> </ul>	5
use	the properties above to test four quadrilaterals to determine if they are parallelograms	4
write	a two-column proof and a paragraph proof for the following theorem: If one pair of opposite sides of a quadrilateral are parallel and congruent, then the quadrilateral is a parallelogram.	2
prove	that a quadrilateral with four congruent sides is a parallelogram	1
Venn diagram	characteristics of a rhombus, a parallelogram, and both	3

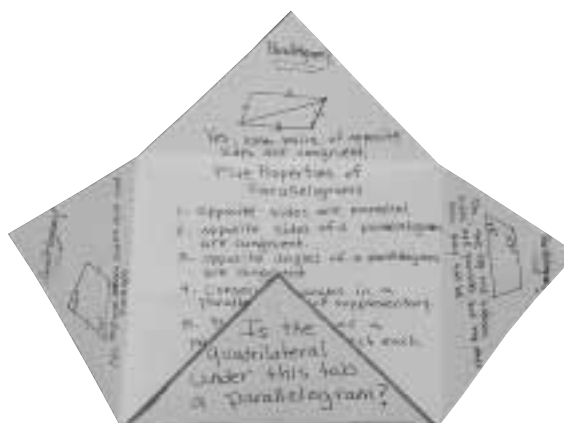

# Trapezoids

Skill	Activity Suggestion	Foldable Parts
define	a trapezoid as a quadrilateral with exactly two parallel sides called bases	1
draw	a trapezoid and label the bases, legs, and height or the altitude	2
explain	how you can use triangles to find the area of different trapezoids	any number
describe	how to find the area of a trapezoid in words and symbols	2
compare and contrast	the altitude of a triangle and the altitude of a trapezoid	2
draw	a parallelogram, a triangle, and a trapezoid with the same area on grid paper	3
illustrate	the diagonals in given trapezoids	any number
construct	the median of a trapezoid and outline the steps	2
compare	an isosceles triangle and an isosceles trapezoid	2
Venn diagram	characteristics of an isosceles trapezoid, a non-isosceles trapezoid, and both	3
recognize	the properties of trapezoids: <ul style="list-style-type: none"> <li>• the bases are parallel</li> <li>• the median is parallel to the bases and its measure is half of the sum of the measures of the bases</li> </ul>	2

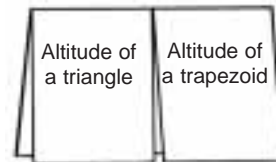

Two-Tab Book

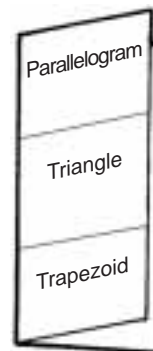

Three-Tab Book

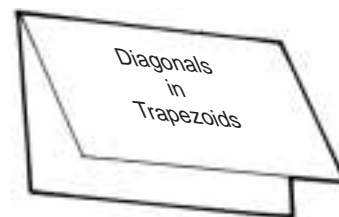

Half Book

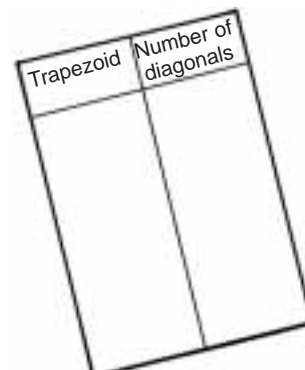
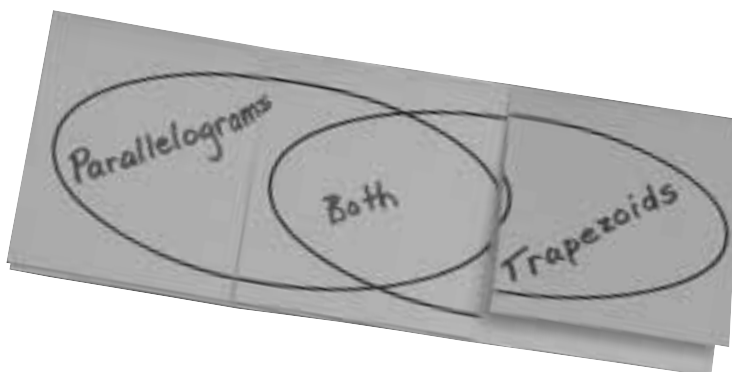

Folded Chart

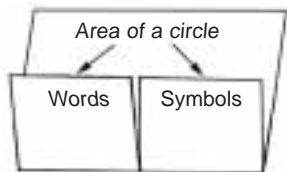

Two-Tab Concept Map

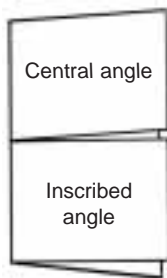

Two-Tab Book

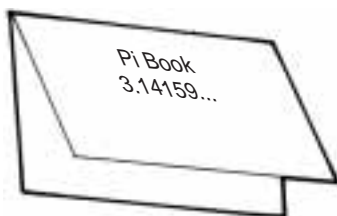

Half Book

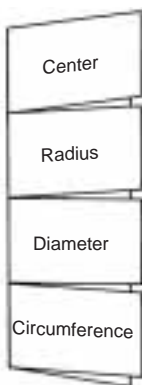

Four-Tab Book

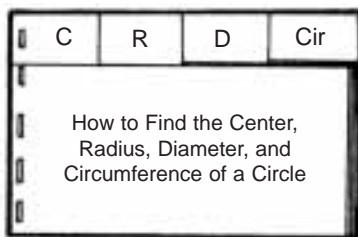

Top-Tab Book

# Circles

Skill	Activity Suggestion	Foldable Parts
use	a compass to draw circles	any number
define	center, radius, diameter, and circumference	4
label	the center, radius, diameter, and circumference of a circle	4
explain	how to find the radius of a circle if the diameter is known	any number
draw	three circles on grid paper and estimate their areas by counting grid squares	3
find	the circumference of a circle if given the radius and find the circumference given the diameter	2
	the area of a circle	any number
describe	in words and symbols how to find the area of a circle	2
explain	how to find the area of a circle if you know the measure of the radius	1
investigate	the history of and the use of pi, or 3.14159...	2
explain	why pi is not a rational number and give rational numbers that could be used as approximations for pi	2
illustrate	three chords of a circle	3
describe	the diameter of a circle as the longest chord that can be drawn and illustrate	2
illustrate	a central angle of a circle and describe it as an angle whose vertex is the center of a circle	2
label and measure	a central angle and the major and minor arcs it intercepts	2
compare and contrast	a central angle and an inscribed angle	2
use a compass	to draw a semicircle	1
differentiate	between concentric circles and congruent circles	2
	chords, tangents, and secants	2
recognize	tangents and use properties of tangents	2

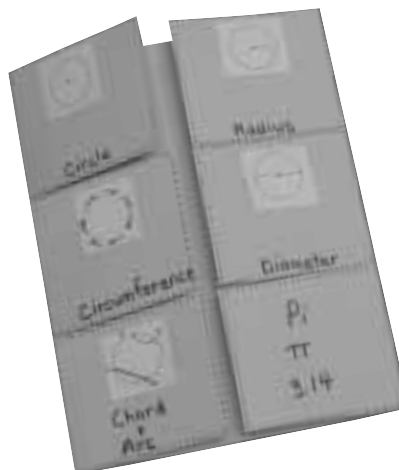

# Three-Dimensional Figures

Skill	Activity Suggestion	Foldable Parts
identify	three-dimensional figures	any number
Venn diagram	characteristics of two-dimensional figures, three-dimensional figures, and both	3
explain	surface area and volume as they relate to three-dimensional figures	2
list	examples of ways in which you use surface area and volume in your daily life	2
describe	how surface area is measured by square units and volume is measured in cubic units	2
use	top, front, side, and corner views of three-dimensional solids to make models	
draw	pyramids, cones, cylinders, and prisms	4
define	polyhedron and give three examples	3
illustrate	the five types of regular polyhedra, also called the Platonic solids	5
name	the edges, faces, and vertices of polyhedrons you draw	any number

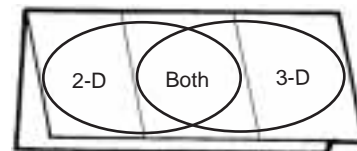

Three-Tab Venn Diagram

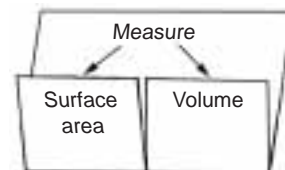

Two-Tab Concept Map

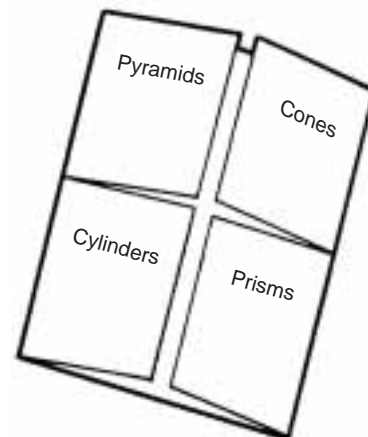
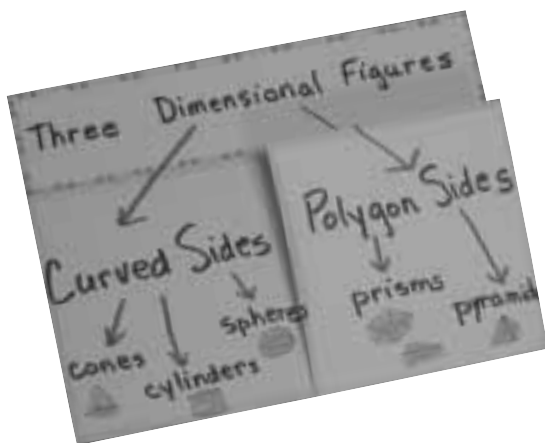

Four-Door Book

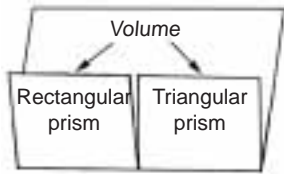

Two-Tab Concept Map

## Prisms and Cylinders

Skill	Activity Suggestion	Foldable Parts
define	prism as a solid figure that has two parallel congruent sides, called bases	1
explain	why you think prisms are named by the shape of their bases	1
draw	examples of rectangular prisms and triangular prisms	2
show	the nets of a rectangular and a triangular prism	2
find	the surface area of a rectangular prism	1
find	the surface area of a triangular prism	1
find	the volumes of a rectangular prism and a triangular prism	2
describe	in words and symbols how to find the volume of a prism	2
list	examples of prisms you encounter in your daily life	any number
define	cylinder as a three-dimensional shape with two parallel, congruent, circular bases	1
draw	a cylinder and label the bases and an altitude	2
list	examples of cylinders you encounter in a week's time	any number
show	the net of a cylinder	1
find	the surface area of a cylinder	1
find	the volume of a cylinder	1
describe	in words and symbols how to find the volume of a cylinder	2
Venn diagram	method for finding the volume of a prism, the volume of a cylinder, and both	3

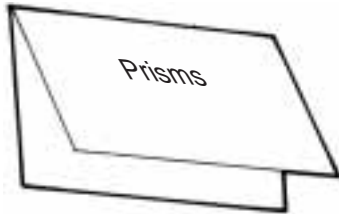

Half Book

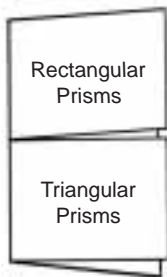

Two-Tab Book

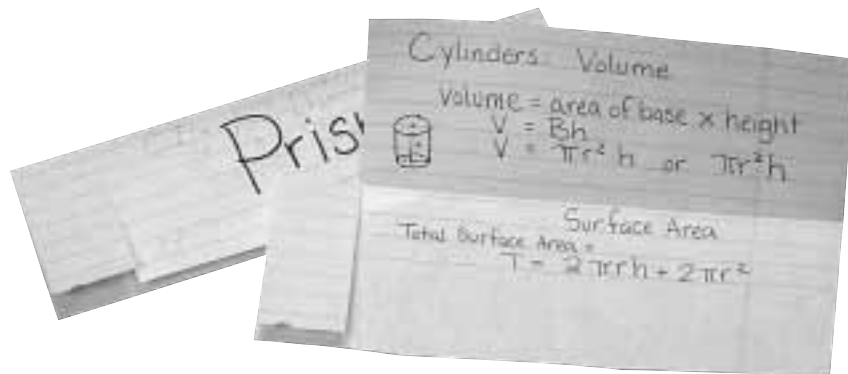



## Pyramids and Cones

Skill	Activity Suggestion	Foldable Parts
define	pyramid as a solid figure that has a polygon for a base	1
explain	why you think pyramids are named by their bases	1
compare and contrast	a square pyramid and a triangular pyramid	2
describe	a pyramid's base, lateral faces, and vertex	3
illustrate	a pyramid's slant height and a pyramid's net	2
find	the surface area of a rectangular or triangular pyramid	1
	the volume of a rectangular or triangular pyramid	1
describe	in words and symbols how to find the volume of a pyramid	2
define	cone as a three-dimensional shape with a circular base and one vertex	1
show	the slant height and the net of a cone	2
explain	in your own words how to find the surface areas of a cone and a pyramid	2
describe	in words and symbols how to find the volume of a cone	2
Venn diagram	characteristics of a cone, a pyramid, and both	3

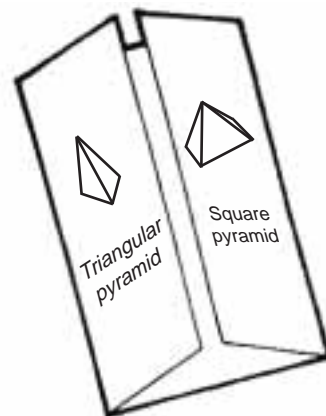

Shutter Fold

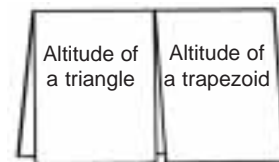

Two-Tab Book

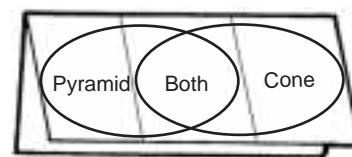

Three-Tab Venn Diagram

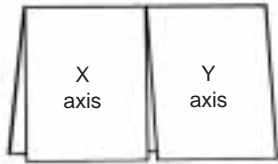

Two-Tab Book



Three-Tab Book

## Coordinate Geometry

Skill	Activity Suggestion	Foldable Parts
describe	a coordinate system as the intersection of two number lines that meet at their zero points	1
explain	how a point can be located using a coordinate system	1
define	origin as the intersection point of two number lines at their zero points	1
differentiate between	the $x$ -axis and the $y$ -axis	2
draw	a coordinate system and label the origin, $x$ -axis, and $y$ -axis	2
describe	how to use an ordered pair to graph a point on a coordinate system	1
mark and name	points on a grid	any number
name	the ordered pairs for given points a grid	any number
find	examples of coordinate systems used in your daily life	any number
Venn diagram	characteristics of latitude lines, longitude lines, and both	3
describe	how the two axes of a coordinate system to divide the coordinate plane into four regions called quadrants	4
draw	a coordinate system and label the origin, axes, and quadrants	3
explain	what it means to graph or plot a point	1
plot	points such as $(5, 7)$ and $(7, 5)$ and explain how they differ	any number
graph	points on a coordinate plane and name them	any number

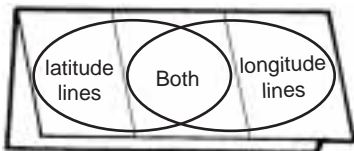

Three-Tab Venn Diagram



# Slope

Skill	Activity Suggestion	Foldable Parts
define	the slope of a line	1
differentiate between	the vertical change, or the change in $y$ , and the horizontal change, or the change in $x$	2
find	the slope of a line when given two points on the line	any number
explain	in words and symbols how to find the slope of a line	2
illustrate	the rise (vertical change) and the run (horizontal change) of a line	2
describe	slope as "rise over run"	1
define	parallel lines as lines that will never intersect	1
explain	the relationship between the slopes of parallel lines	1
make a conjecture	about the slopes of perpendicular lines	1

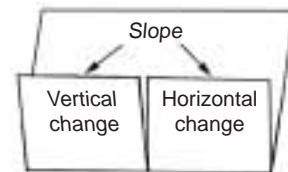

Two-Tab Concept Map

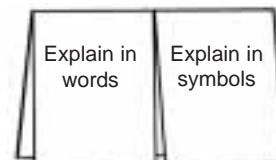

Two-Tab Book

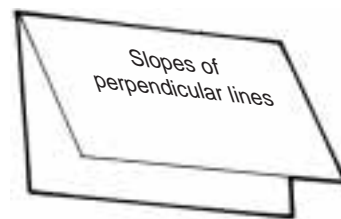
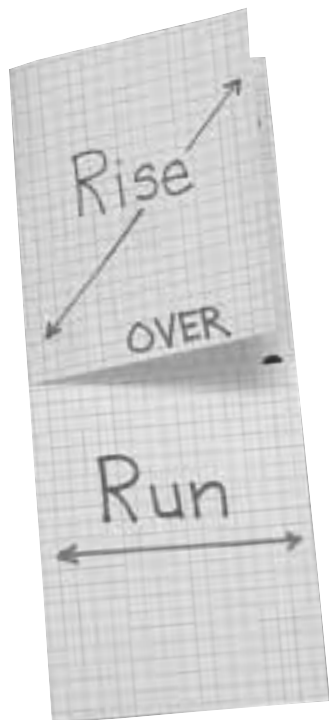

Half Book

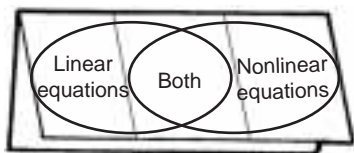

Three-Tab Venn Diagram

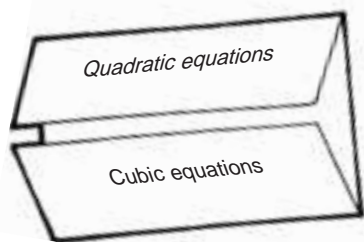

Shutter Fold

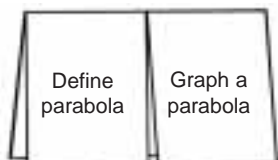

Two-Tab Book

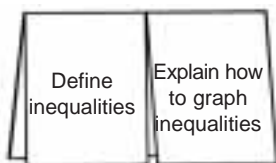

Two-Tab book

## Graphing Equations and Inequalities

Skill	Activity Suggestion	Foldable Parts
graph	linear equations in two variables	any number
find	the $x$ - and $y$ -intercepts of graphs	any number
graph	linear equations using the $x$ - and $y$ -intercepts	any number
Venn diagram	characteristics of linear equations, nonlinear equations, and both	3
compare and contrast	quadratic equations and cubic equations	2
explore	the characteristics of slope	1
find	the slope of a line given its equation	any number
investigate	rate of change	1
graph	linear inequalities	any number
define	parabola	1
illustrate	the graph of a parabola	1
use	tables and graphs to write linear functions	2
define	inequalities	1
explain	how to graph inequalities	1

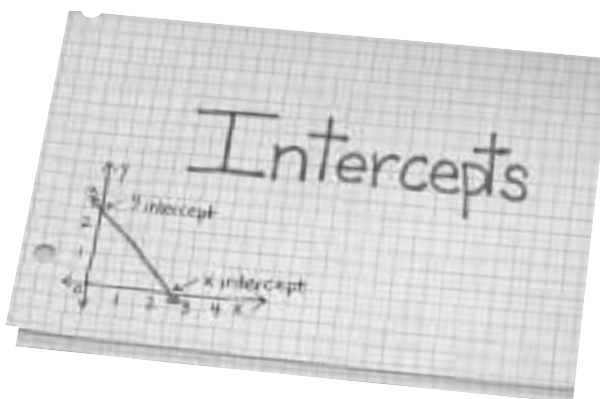

## Metric Measurement

Skill	Activity Suggestion	Foldable Parts
investigate	the development of the metric system of measurement by French scientists in 1795	1
define	a meter (m) as $\frac{1}{10,000,000}$ of the distance between the North Pole and the Equator	1
chart	the prefixes used with the metric system	any number
note	each place value is 10 times the place value to its right	any number
make	a place value chart for the metric system	any number
convert	measurements within the metric system	any number
	Customary units to metric units	any number

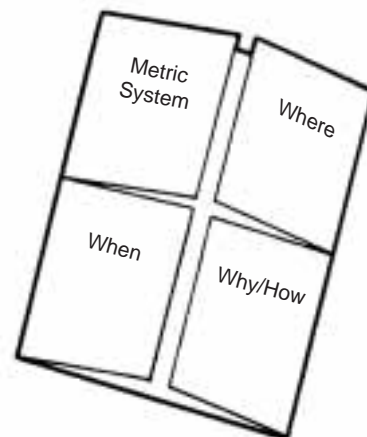

Four-Door Book

## Length, Width, and Height

Skill	Activity Suggestion	Foldable Parts
research	the history of the measurement of length, width, and height	3
explain	inches, feet, yards	3
	millimeters, centimeters, meters	3
write	word problems based upon length and width	any number
	measurements in numbers and words	any number
read	Customary and metric measurements of length and width	2
	instruments used to record length, width, and height	any number
record	common uses of length and width	any number

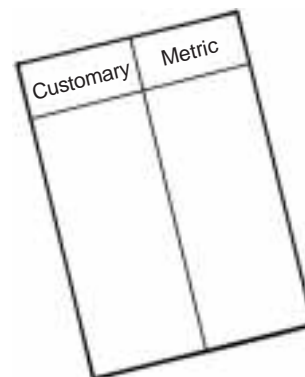

Folded Chart

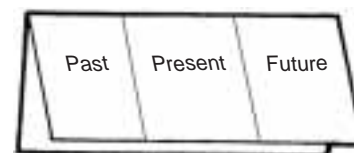

Three-Tab Book

## Distance

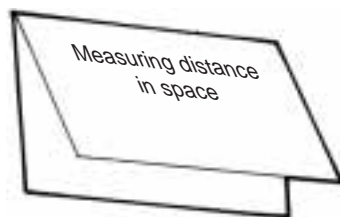

**Half Book**

Skill	Activity Suggestion	Foldable Parts
define	distance as the space between two points or locations	1
research	the history of the measurement of distance	any number
explain	inches, feet, yards, miles	4
	centimeters, meters, kilometers	3
write	word problems based upon distance	any number
read	instruments used to measure distance	any number
investigate	light-years and explain how and why this unit of measurement was developed	2
	astronomical units (AU)	1
	microns, or millionths of a meter, and millimicrons, or thousandths of a micron	2

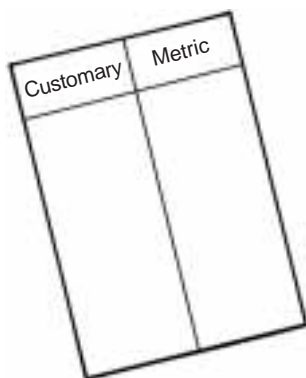

**Folded Chart**

## Weight

Skill	Activity Suggestion	Foldable Parts
define	weight as the gravitational force, or pull, on an object	1
explain	why objects have no weight in space	1
	why objects on a planet smaller than Earth would weigh less than they do on Earth	1
investigate	common units of weight measurement: ounce/pound and gram/kilogram	2
estimate	weight based upon experiences	any number



**Two-Tab Book**

## Volume

Skill	Activity Suggestion	Foldable Parts
define	volume as the amount of space something occupies	1
compare and contrast	the measurement of volume of a solid and a liquid	2
find	the volume of two rectangular solids by using the formula $V = \ell wh$	2
	the volume of a cylinder using the formula $V = \pi r^2 h$	1
	the volume of a sphere using the formula $V = \frac{4}{3} \pi r^3$	1
evaluate	the number of cubic inches in a cubic foot and the number of cubic centimeters in a cubic meter	2
describe	how liquids are measured in the customary system and in the metric system	2
use	gallons, quarts, pints, and fluid ounces	4
	liters and milliliters	2

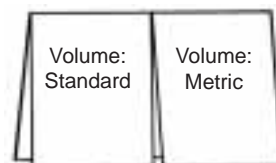

Two-Tab Book



Three-Tab Book

## Temperature

Skill	Activity Suggestion	Foldable Parts
research	the history of the measurement of temperature	any number
write	three word problems based upon temperature	3
read	and report metric and customary system measurements of temperature	2
differentiate	between degrees Celsius and degrees Fahrenheit	2
research and graph	the average body temperatures of five animals	5
make a table	of average air temperatures of different geographic regions or areas	any number
	of average surface and core temperatures of the planets in our solar system	2
record	temperatures at predetermined intervals over a given period of time	2
read	instruments used to measure temperature	any number
investigate	the International Temperature Scale of 1990	1
	Kelvin, K, the unit of thermodynamic temperature	1
	absolute zero, $-273.15^{\circ}\text{C}$ or $-459.67^{\circ}\text{F}$	1

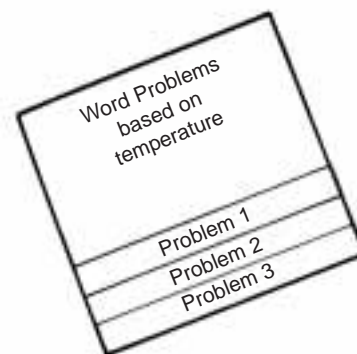

Layered-Look Book  
(2 sheets of paper)

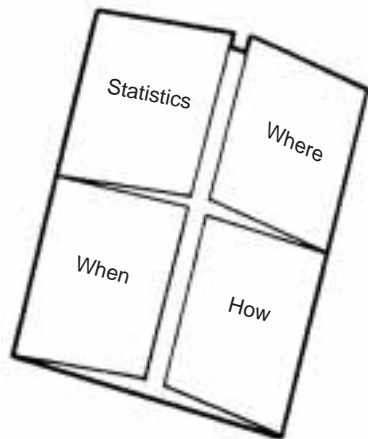

**Four-Door Book**

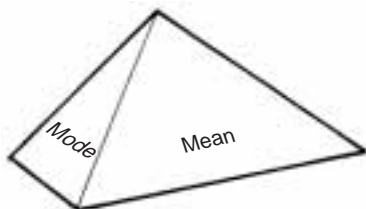

**Pyramid Fold**

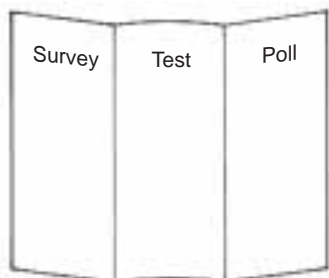

**Trifold Book**



**Three-Tab Book**

## Statistics

Skill	Activity Suggestion	Foldable Parts
define	statistics as a branch of mathematics that involves collecting and presenting data	1
describe	ways in which statisticians collect and present data	2
define	mean, median, and mode individually and collectively as measures of central tendency of a set of data	3
analyze	data using mean, median, and mode	3
find	the mean and median for a set of data	2
explain	the range of a set of numbers	1
determine	the range of a set of data	any number
separate	a large set of data into four equal parts, or quartiles	4
illustrate	how the median of a set of data divides the data in half	2
write	the definition of interquartile range in words and symbols	2
sequence	the steps for finding the range and interquartile range of a set of data. 1. List the data from least to greatest. 2. Find the median. 3. Find the upper quartile, or the median of the upper half. 4. Find the lower quartile, or the median of the lower half. 5. Find the interquartile range by subtracting the upper quartile range from the lower quartile range.	5
use	measures of variation to compare data	any number
list	ways in which measures of variation are used in everyday life or in a work place	any number
find	the range, median, upper quartile, lower quartile, and the interquartile range for sets of data	5
describe	how statistics are used in written and oral communication to prove points and influence opinions	2
explain	ways in which statistics might be misleading	any number
recognize	and find examples of misleading statistics	any number
find	examples of graphs in a newspaper or magazine, determine if they are or are not misleading, and explain why or why not	2
list	things you might question when reading the results of a survey, test, or poll	any number
use	the same data with two different scales and explain how these graphs look different	2



## Stem-and-Leaf Plots

Skill	Activity Suggestion	Foldable Parts
describe	a stem-and-leaf plot	1
define	the stem and leaf	2
illustrate	how to organize data into stems and leaves	2
explain	the purposes of the “stem” and the “leaf”	2
show	how data values with numerous digits can be rounded so that each leaf has only one digit	1
collect	data that can be organized into a stem-and-leaf plot, such as student grades on a test	any number
display	data in stem-and-leaf plots	any number
sequence	the steps used for making a stem-and-leaf plot	any number
interpret	data presented in stem-and-leaf plots made by classmates	any number
compare and contrast	a regular stem-and-leaf plot and a back-to-back stem-and-leaf plot	2
make	a back-to-back stem-and-leaf plot	1
Venn Diagram	characteristics a stem-and-leaf plot, a bar graph, and both	3

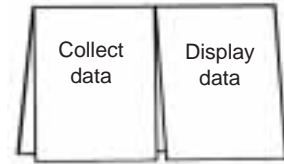

Two-Tab Book

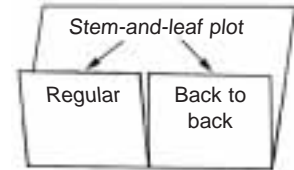

Two-Tab Concept Map

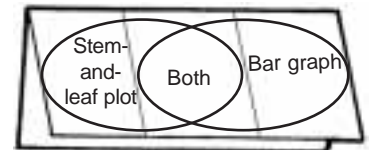

Three-Tab Venn Diagram

## Box-and-Whisker Plots

Skill	Activity Suggestion	Foldable Parts
define	quartiles and extreme values of a set of data as each relate to a box-and-whisker plot	2
display	data in box-and-whisker plots	any number
explain	the purpose for using box-and-whisker plots and describe how they present important characteristics of data visually	1
sequence	the steps for constructing a box-and-whisker plot. 1. Draw a number line for the range of the data. 2. Above the number line, mark points for the upper and lower extremes, the median, and the upper and lower quartile values. 3. Draw a box that contains the quartile values. 4. Draw a vertical line through the median value. 5. Extend the whiskers from each quartile to the upper and lower extreme data points.	5
list	five things that can be learned from a box-and-whisker plot	5
define	outliers as data that are more than 1.5 times the interquartile range from the quartiles	1
Venn Diagram	characteristics of a box-and-whisker plot, a stem-and-leaf plot, and both	3

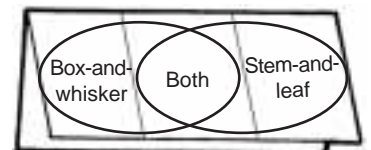

Three-Tab Venn Diagram

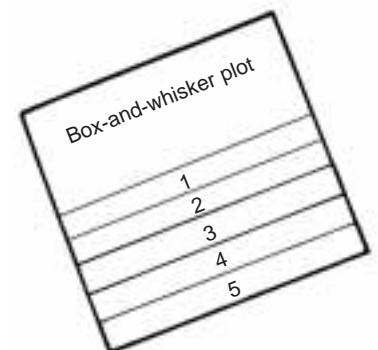

Layered-Look Book  
(3 sheets of paper)

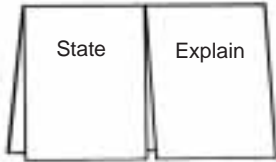

Two-Tab Book



Two-Tab Book

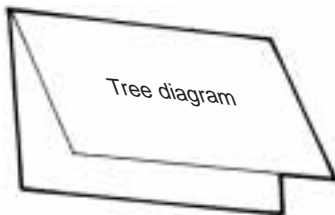

Half Book



Two-Tab Book

## Fundamental Counting Principle

Skill	Activity Suggestion	Foldable Parts
explain	the Fundamental Counting Principle	1
draw	a tree diagram to show the possible outcomes for two events, such as tossing a dime and then tossing a nickel, and explain your drawing	2
describe	independent events and dependent events as they relate to the Fundamental Counting Principle	2

## Frequency Tables

Skill	Activity Suggestion	Foldable Parts
describe	the purpose of a frequency table	1
differentiate between	a frequency table and a bar graph	2
explain	why a frequency table is good when you want to know specific numbers	1

## Pascal's Triangle

Skill	Activity Suggestion	Foldable Parts
define	the following terms as they relate to Pascal's triangle: expand powers, binomials, binomial theorem, exponents, coefficients	5
explain	Pascal's triangle in your own words	1
	the Binomial Theorem in your own words	1
describe	how to form two additional rows of Pascal's triangle	2
research	the "who, what, where, when" of: Blaise Pascal and Pascal's triangle	4
	Sir Isaac Newton and his discovery of ways in which the Binomial Theorem can lead to an infinite series	4
make a timeline	of the history of this triangle	any number

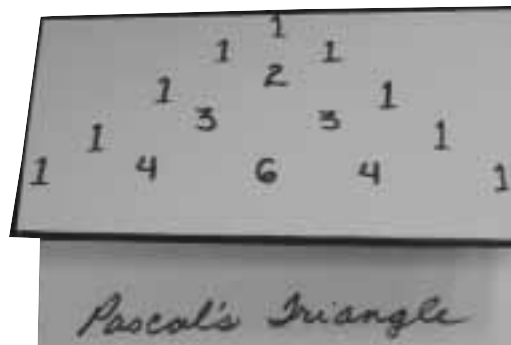

## Permutations

Skill	Activity Suggestion	Foldable Parts
define	permutation as an arrangement or listing in which order is important	1
use	the symbol $P(6, 3)$ to represent the number of permutations of 6 things taken 3 at a time	1
find	values for problems such as $P(5, 5)$ and make models to illustrate their meaning	2
observe	two ways in which you might use permutations in your daily life	2
list	three examples of permutations	3
write	four permutations as word problems	4
differentiate	between linear permutations and circular permutations	2
explain	the rule for permutations with repetitions in writing and give an example	2
determine	whether something is a combination or a permutation	2

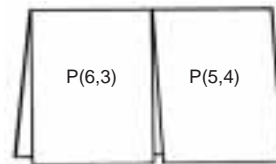

Two-Tab Book

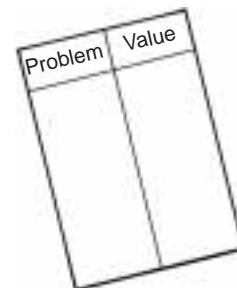

Folded Chart

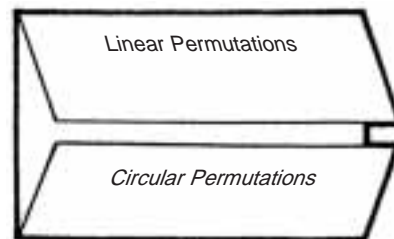

Shutter Fold

## Combinations

Skill	Activity Suggestion	Foldable Parts
differentiate between	permutations and combinations	2
summarize	the difference between a permutation and a combination of 3 things taken 2 at a time	2
draw	models to illustrate two combinations	2
define	combinations as arrangements or listings where order is not important	1
use	the symbol $C(6, 3)$ to represent the number of combinations of 6 things taken 3 at a time	any number
observe	ways in which you might use combinations in your daily life	any number
list	examples of combinations	any number
find	values for problems such as $C(5, 4)$	any number
write	word problems involving combinations	any number

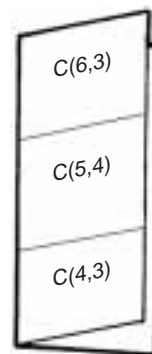

Three-Tab Book

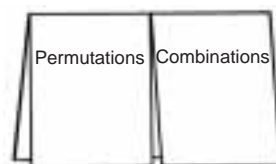

Two-Tab Book

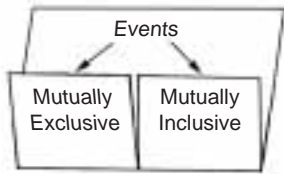

Two-Tab Concept Map

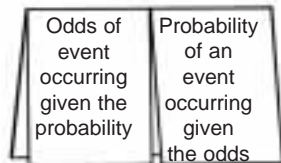

Two-Tab Book

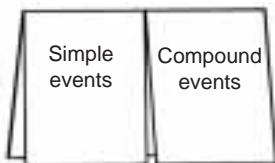

Two-Tab Book

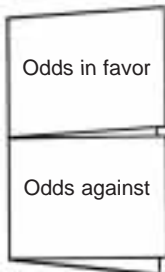

Two-Tab Book

# Probability

Skill	Activity Suggestion	Foldable Parts
define	probability as the chance that some event will happen	1
describe	probability as the ratio of the number of ways a certain event can occur to the number of possible outcomes	1
explain	the set of all possible outcomes as the sample space	1
find	the probability of three simple events	3
	the probability of two compound events	2
describe	the probability of two independent events in words and symbols	2
	the probability of two dependent events in words and symbols	2
define	the term <i>odds</i> as a way to describe the chance of an event occurring	1
explain	odds in favor and odds against	2
	probability of success and failure	2
differentiate	between probability and odds	2
give	examples of mutually exclusive events	any number
describe	how to find the probability of mutually exclusive events in words and symbols	2
define	inclusive events and give two examples	2
describe	how to find the probability of inclusive events in words and symbols	2
compare and contrast	mutually exclusive and inclusive events	2
	dependent and independent events	2
make	a vocabulary book for the following terms: dependent events, experimental probability, inclusive, independent events, mutually exclusive, odds, relative frequency, simulation	8
state	the odds of an event occurring given the probability and the probability of an event occurring given the odds	2

# Scatter Plots

Skill	Activity Suggestion	Foldable Parts
define	a scatter plot as a graph that shows the general relationship between two sets of data	1
construct	scatter plots	any number
interpret	scatter plots	any number
differentiate between	scatter plots that show a positive relationship, negative relationship, and no relationship	3
write	about three ways in which scatter plots might be used: display data, examine trends, make predictions	3
describe	how to draw a scatter plot for two sets of data	1
create	a scatter plot to analyze data	1
draw	lines of fit for sets of data on a scatter plot	1
use	lines of fit to make predictions about data	1
define	and determine a prediction equation	2

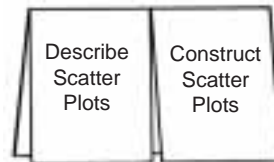

Two-Tab Book

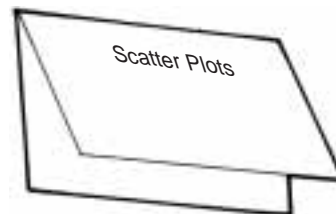

Folded Book

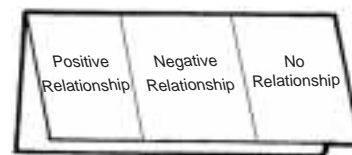

Three-Tab Book

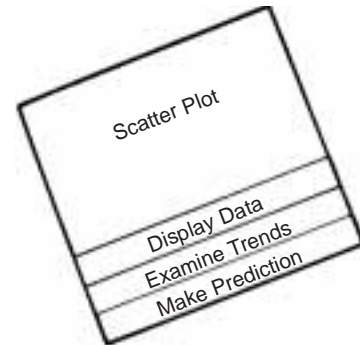

Layered-Look Book  
(2 sheets of paper)

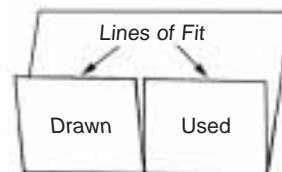

Two-Tab Concept Map

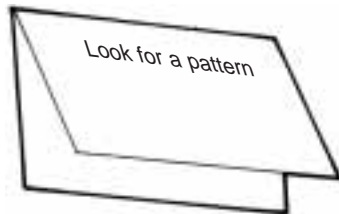

**Half Book**

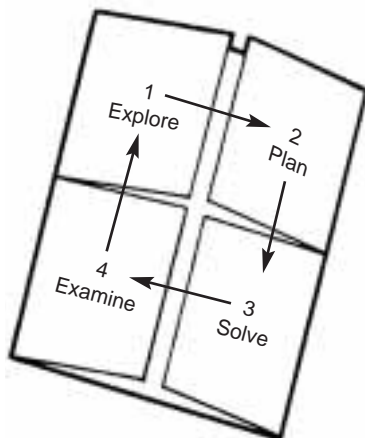

**Four-Door Book**

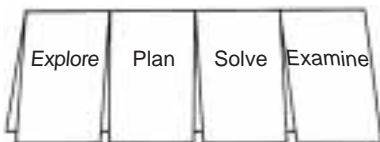

**Four-Tab Book**

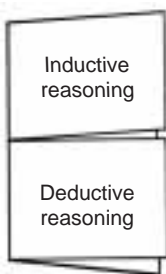

**Two-Tab Book**



**Folded Chart**

## Problem-Solving Plan

Skill	Activity Suggestion	Foldable Parts
describe	the four steps of the problem-solving plan in writing	4
solve	problems using the four-step problem-solving plan	any number
explain	how the four-step plan gives you an organized method for solving problems	1
demonstrate	how to use the problem-solving plan	1
choose	appropriate methods of computation when using the problem-solving plan	4
describe	how looking for a pattern is a good problem-solving technique	1

## Problem-Solving Strategies

Skill	Activity Suggestion	Foldable Parts
give	three examples of inductive reasoning	3
	three examples of deductive reasoning	3
compare and contrast	inductive and deductive reasoning	2

## Vocabulary and Writing Definitions

Skill	Activity Suggestion	Foldable Parts
explain	the meaning of a word or process in your own words	1
define	terms by giving written examples	any number
	terms orally, in writing, and algebraically	3
write	the definition of terms concisely	any number
	a descriptive paragraph using the vocabulary words and concepts introduced in a lesson	1
use	vocabulary words in your speech and writing as frequently as possible	any number
	a dictionary to find definitions of your math vocabulary words and compare the dictionary definition to the definition given in your textbook	2
	the Internet to find definitions and examples of properties, or functions	3
self-check	your knowledge of terms and concepts by observing a word and mentally defining it	any number
quiz	friends and family members to see if they know the meaning of your vocabulary words	any number

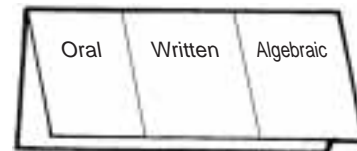

Three-Tab Book

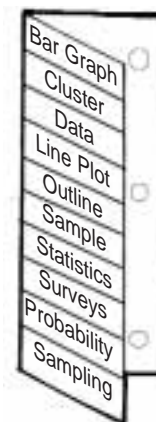

Vocabulary Book

## Journals

Skill	Activity Suggestion	Foldable Parts
explain	descriptively what you are learning	1
define	terms, concepts, properties, and more in your math journal	any number
write	about personal associations and experiences called to mind during the learning process	any number
evaluate	the direction and progress of your learning in your journal	1
list	examples of ways in which new knowledge has or will be used in daily life experiences	any number
read	journal notes of fellow students and compare their experiences with your own	2
describe	positive and negative experiences during your learning process	2
use	journals for self-questioning by recording questions that arise during learning	any number
	journals to organize thinking by including sketches, diagrams, and examples	any number

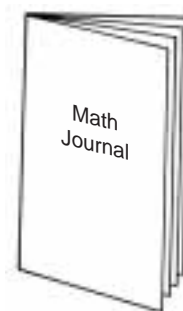

Bound Book

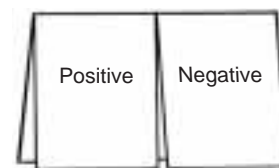

Two-Tab Book



**Three-Tab Book**

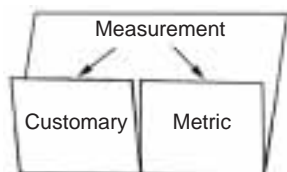

**Concept Map**



**Half Book**



**Layered-Look Book**

## Outline, List, and Sequence

Skill	Activity Suggestion	Foldable Parts
note	the order in which concepts are presented in lessons and texts	1
explain	why certain concepts are presented in a specific sequence	1
	why there is an order of operations	1
describe	an order of operations as a sequence and describe its importance	2
outline	the steps used to solve given problems	any number
	how several students reached a solution and compare and contrast the outlines	any number
	the main ideas and supporting facts presented in a lesson or chapter	any number
list	examples of specific things studied, such as operations, processes, properties, and more	any number

## Concept Maps

Skill	Activity Suggestion	Foldable Parts
explain	the use of a concept map	1
design	a concept map to organize information presented in a lesson or text chapter	any number
use	a concept map as a study guide to review main ideas and supporting information	any number

## Writing Instructions

Skill	Activity Suggestion	Foldable Parts
explain	the importance of writing clear, concise instructions	1
write	a set of instructions on how to do something presented in a lesson	any number
ask	students to follow their own instructions to check them for accuracy and clarity	2
	students to follow instructions written by classmates to check them for accuracy and clarity	2



## Main Ideas and Note Taking

Skill	Activity Suggestion	Foldable Parts
determine	main ideas	any number
outline	main ideas and supporting information or facts	any number
describe	note taking as a skill that is based upon listening or reading for main ideas and then recording these ideas for future reference	1
use	a journal to take notes on a specific topic	any number
	a concept map to record a main idea and supporting facts	any number



Bound Book

## Annotations

Skill	Activity Suggestion	Foldable Parts
write	annotations or notes to organize the text they are reading for review or study	any number
write	annotations that include the following: key points highlighted or copied into a journal reader questions that arise reader comments reader reactions to text short summaries steps or data numbered by reader	any number

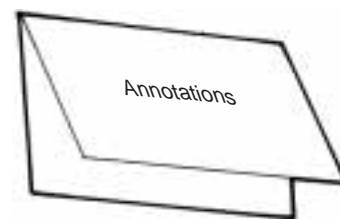

Half Book

## Questioning

Skill	Activity Suggestion	Foldable Parts
note	different ways in which questioning is used in the learning process	any number
develop	the skill of self questioning during learning	2
write	personal questions that arise during learning	1
practice	asking questions in a clear and concise manner	any number
differentiate	between questions that can be answered using <i>yes</i> or <i>no</i> responses to those that are open ended	2
find	examples of the following: questions without answers questions that have only one answer questions with multiple answers	3
formulate	questions that can be addressed with data and collect, organize, and display data to answer the questions	any number

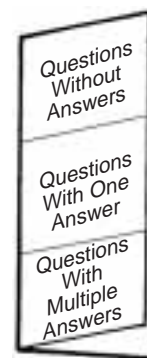

Three-Tab Book

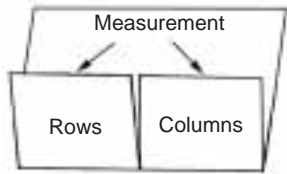

**Concept Map**



**Half Book**

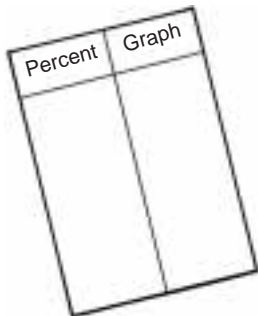

**Folded Chart**

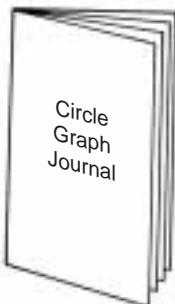

**Bound Book**

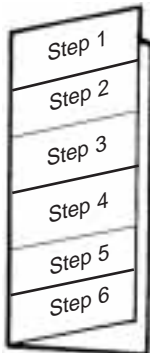

**Six-Tab Book**

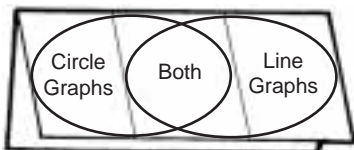

**Venn Diagram**

## Tables and Charts

Skill	Activity Suggestion	Foldable Parts
chart	information using rows or columns	any number
describe	a data table as having rows and columns	1
	the importance of labeling the title of a data table and labeling the rows and columns	1
make	a data table	any number
outline	steps taken to make a specific data table	any number
write	information in the appropriate columns and rows of a data table	any number
use	data collected in a table to write a summary	1

## Circle Graphs

Skill	Activity Suggestion	Foldable Parts
explain	how circle graphs show the parts of something as they relate to the whole	1
	why circle graphs are also called pie graphs or pie charts	1
make and label	a circle graph based upon data expressed as percents	2
	a circle graph based upon data that is not expressed as percents	2
convert	data into percents and report it using a circle graph	any number
describe	each section of a circle graph as a segment of the circle	2
use	a protractor to measure the central angles of three circle graphs	1
	a protractor to draw the central angles of three circle graphs	1
sequence	the steps for converting data into percents so it can be presented using a circle graph	6
Venn diagram	characteristics of circle graphs, bar graphs, and both	3

## Bar Graphs and Histograms

Skill	Activity Suggestion	Foldable Parts
describe	a histogram as a bar graph that shows the frequency distribution of data	1
make and label	a bar graph	2
	a histogram	2
explain	single and double bar graphs	2
define	a double bar graph as a comparative graph	1
explain	how a double bar graph can be used to show trends	1
make and label	a double bar graph	2
use	a bar graph to compare increases and decreases in quantity over a period of time	2
collect	examples of bar graphs encountered in daily life	any number

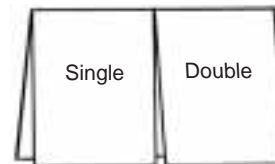

Two-Tab Book

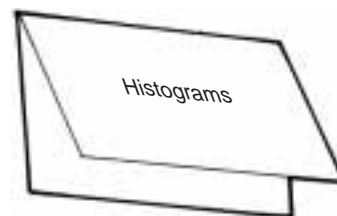

Half Book

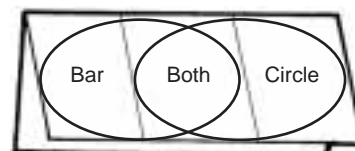

Venn Diagram

## Line Graphs

Skill	Activity Suggestion	Foldable Parts
explain	how line graphs can be used to show how values change over a period of time	1
use	line graphs to compare numbers	any number
	line graphs to show trends or patterns	any number
develop	a grid and make your own line graph	1
label	and explain the vertical and horizontal axes of your line graph	2
describe	which axis shows frequency and which shows categories	2
	what the points on a line graph indicate and explain why straight lines are used to connect the points	2
make and label	line graphs to show the following: <ul style="list-style-type: none"> <li>• student grades over a period of time</li> <li>• production level or sales over time</li> <li>• population of an area over time</li> <li>• income over time</li> </ul>	2

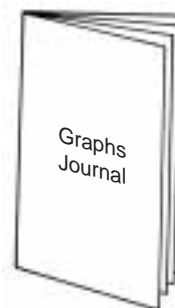

Bound Book

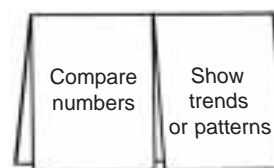

Two-Tab Book

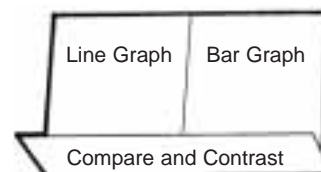

Matchbook

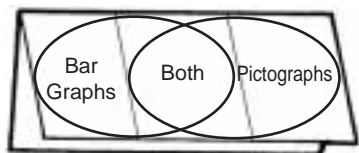

**Venn Diagram**

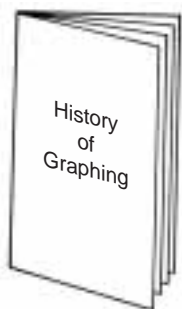

**Bound Book**

## Pictographs

Skill	Activity Suggestion	Foldable Parts
explain	how pictographs use pictures or symbols to show how specific quantities compare	1
make and label	a pictograph and determine what value each symbol will represent	2
research	the historic origins of pictographs	4
compare and contrast	pictographs and bar graphs	2
collect	examples of pictographs and explain their use	any number
list	advantages and disadvantages of using pictographs	2
note	where and how pictographs are used	2

## Venn Diagrams

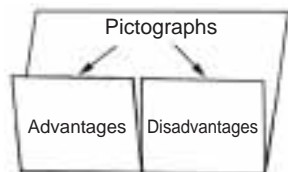

**Concept Map**

Skill	Activity Suggestion	Foldable Parts
explain	how a Venn diagram can be used to display data and show how the data is related	2
	how a Venn diagram can be used to find similarities in data	1
describe	the purpose of a rectangle, circles, and the space formed by overlapping circles in a Venn diagram	3
differentiate between	using a two circle and a three circle Venn diagram	2
make	a Venn diagram to display given data and outline the procedure you used	2
compare and contrast	data presented in a Venn diagram	2
use	Venn diagrams to illustrate two conditional statements	2
write	three conditional statements based upon data illustrated by a Venn diagram: If _____, then _____.	3
draw	a Venn diagram to illustrate data and write four true statements	4

# Index

- absolute value . . . . .36
- angle relationships . . . . .58
  - in polygons . . . . .60
- angles . . . . .58
- area . . . . .61, 65, 66, 67, 68
- bar graphs . . . . .88, 89, 90
- box-and-whisker plots . . . . .79
- charts . . . . .88
- circle graphs . . . . .88
- circles . . . . .68
- circumference . . . . .68
- combinations . . . . .81
- communication . . . . .85–87
  - annotations . . . . .87
  - concept maps . . . . .86
  - journals . . . . .85
  - main ideas . . . . .87
  - note taking . . . . .97
  - outline . . . . .86
  - questioning . . . . .87
  - sequence . . . . .86
  - vocabulary . . . . .85
  - writing definitions . . . . .85
- cones . . . . .71
- coordinate geometry . . . . .72
- cylinders . . . . .70
- decimals . . . . .39, 41, 42
- deductive reasoning . . . . .84
- equations . . . . .48
- exponents . . . . .54
- expressions . . . . .46
- factorization . . . . .51
- factors . . . . .51
- FOIL . . . . .53
- fractions . . . . .35, 39, 40, 41, 42, 43
- frequency tables . . . . .80
- functions . . . . .50
- Fundamental Counting Principle . . . . .80
- geometry . . . . .57–74
  - graphing
    - equations . . . . .74
    - inequalities . . . . .74
    - on a number line . . . . .36
  - histograms . . . . .89
  - inductive reasoning . . . . .84
  - inequalities . . . . .51
  - integers . . . . .36–38
    - adding . . . . .37
    - dividing . . . . .38
    - multiplying . . . . .38
    - subtracting . . . . .37
  - irrational numbers . . . . .44
  - line graphs . . . . .89
  - line segments . . . . .57
  - lines . . . . .57
  - lines of fit . . . . .83
  - matrices . . . . .56
  - mean . . . . .78
  - measurement . . . . .75–77
    - distance . . . . .76
    - metric . . . . .75
    - temperature . . . . .77
    - volume . . . . .77
    - weight . . . . .76
  - measures of central tendency . . . . .78
  - median . . . . .78
  - misleading statistics . . . . .78
  - mode . . . . .78
  - monomials . . . . .53
  - multiples . . . . .52
  - odds . . . . .82
  - order of operations . . . . .46, 54, 86
  - parabola . . . . .74
  - parallelograms . . . . .66
  - Pascal’s triangle . . . . .80
  - percents . . . . .40, 42
  - perimeter . . . . .60, 65
  - permutations . . . . .81
  - pi . . . . .44, 68
  - pictographs . . . . .90
  - planes . . . . .59
  - points . . . . .57
  - polygons . . . . .60
  - polynomials . . . . .53
  - powers . . . . .54
  - prime numbers . . . . .35, 51
  - prisms . . . . .70
  - probability . . . . .82
  - problem solving . . . . .84
  - proof . . . . .65, 66
  - properties . . . . .35, 39, 47, 48, 49
  - proportions . . . . .43
  - pyramids . . . . .71
  - Pythagorean theorem . . . . .62
  - quadrilaterals . . . . .64, 65, 66, 67
  - rate of change . . . . .74
  - rational numbers . . . . .39–41
  - ratios . . . . .43
  - rays . . . . .57
  - real number system . . . . .44
  - rectangles . . . . .65
  - reflections . . . . .60
  - relations . . . . .50
  - rhombi . . . . .65
  - right triangles . . . . .62, 63
  - rotations . . . . .60
  - scatter plots . . . . .83
  - scientific notation . . . . .54

sequences . . . . .	.55	tables . . . . .	.56, 88
sets . . . . .	.45	function . . . . .	.50
slope . . . . .	.57, 73, 74	tessellations . . . . .	.60
square roots . . . . .	.44	three-dimensional figures . . . . .	.69
squares . . . . .	.65	transformations . . . . .	.60
statistical graphs . . . . .	.79, 83, 88–90	translations . . . . .	.60
bar graph . . . . .	.89	trapezoids . . . . .	.67
circle graph . . . . .	.88	triangles . . . . .	.61
histogram . . . . .	.89	right triangles . . . . .	.62, 63
line graph . . . . .	.89	trigonometry . . . . .	.63
pictograph . . . . .	.90	variables . . . . .	.45
statistics . . . . .	.78	Venn diagrams . . . . .	.90
stem-and-leaf plots . . . . .	.79	volume . . . . .	.69, 70, 71, 77
surface area . . . . .	.69, 70, 71	whole numbers . . . . .	.35